

# Advantages of HVDC

Why HVDC rather than HVAC?

- Long distances make HVDC cheaper
- Improved link stability
- Asynchronous link
- Right-of-way for an AC Line designed to carry 2,000 MW is more than 70% wider than the right-of-way for a DC line of equivalent capacity.

# Technical Considerations

- Bulk transmission of Power at voltages upto 800kV
- Back-to-back HVDC converters are used to connect two AC systems with different frequencies –two regions where AC is not synchronized
- Submarine Cable Transmission
- Transmission at reduced voltage
- Inherent Overload Capability

# Economical Considerations

## Comparison

	HVDC	HVAC
Terminal Cost	higher ↑	lower ↓
Line Cost	lower ↓	higher ↑
Right-of-Way Cost	lower ↓	higher ↑

## Conclusion

**HVDC** is more **economical** for transmission distances longer than the **break-even distance**

If **capitalisation of losses** and **right-of-way cost** are included in the cost comparison, the **break-even distance** is further **reduced**

# Example Losses on Optimized Systems for 1200 MW

SIEMENS

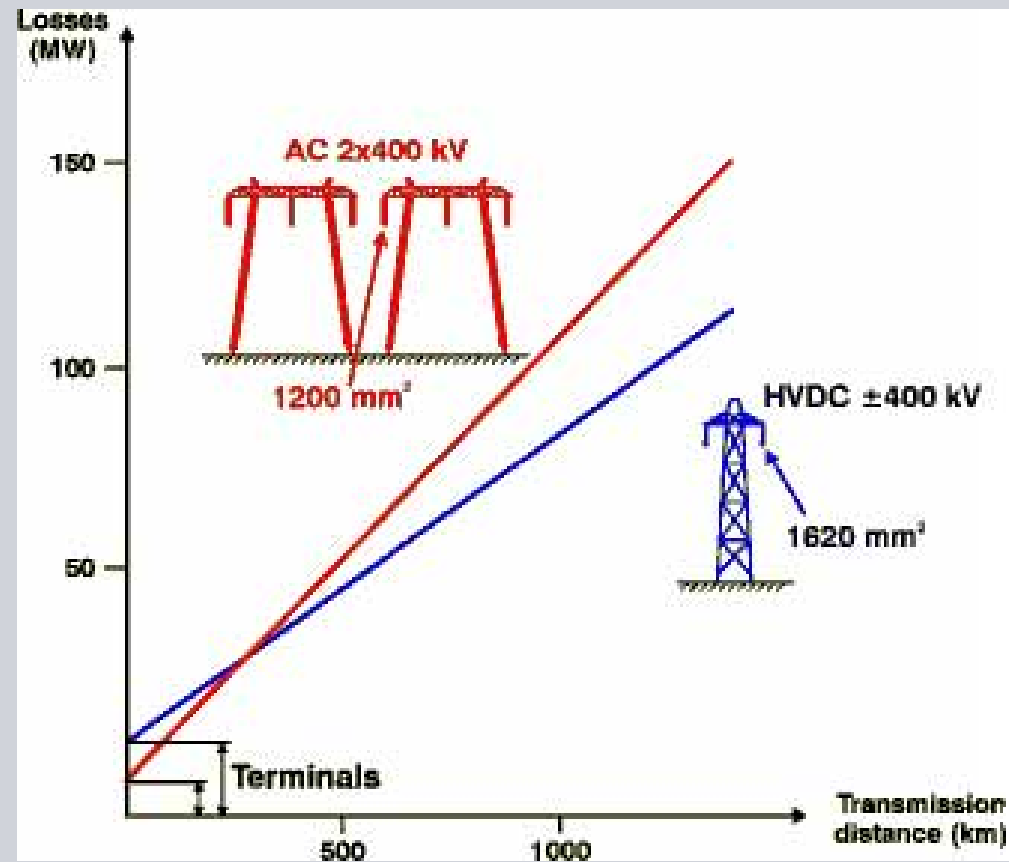

# Economical Considerations

## Capitalised Losses / Break-Even-Distance

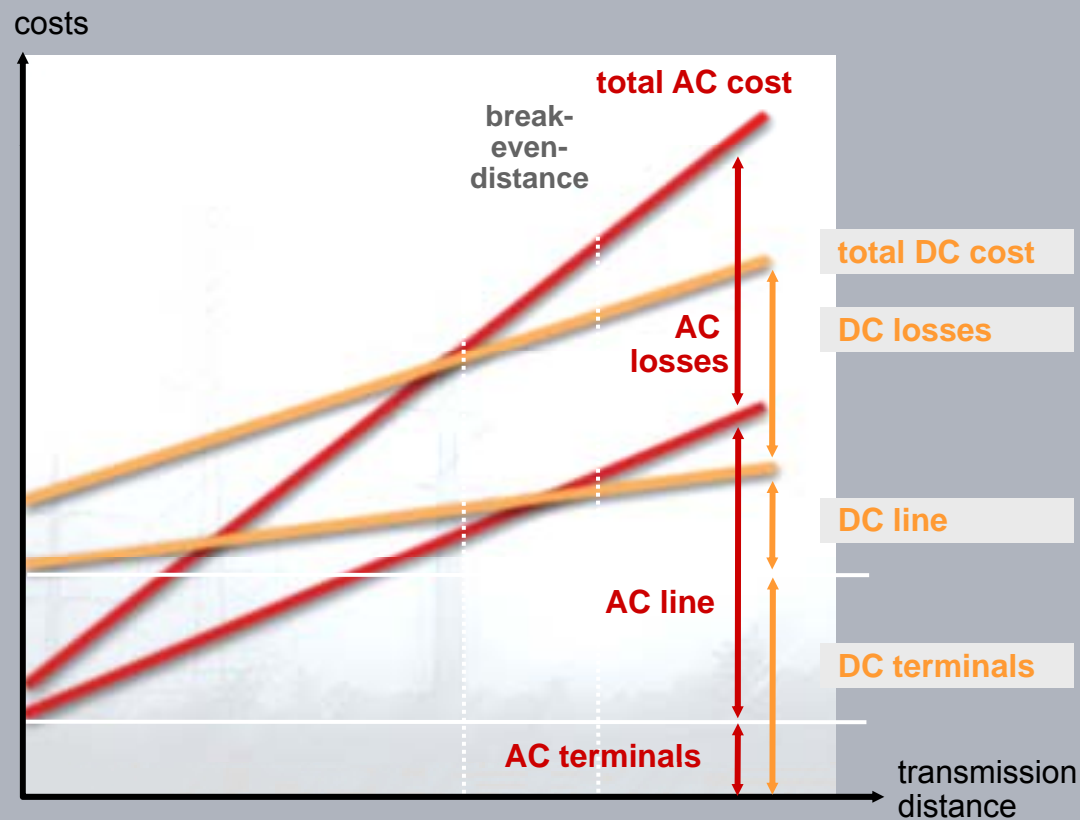

# Economical Considerations

## Right-of-Way

### Typical Transmission Line Structures for approx. 2000 MW

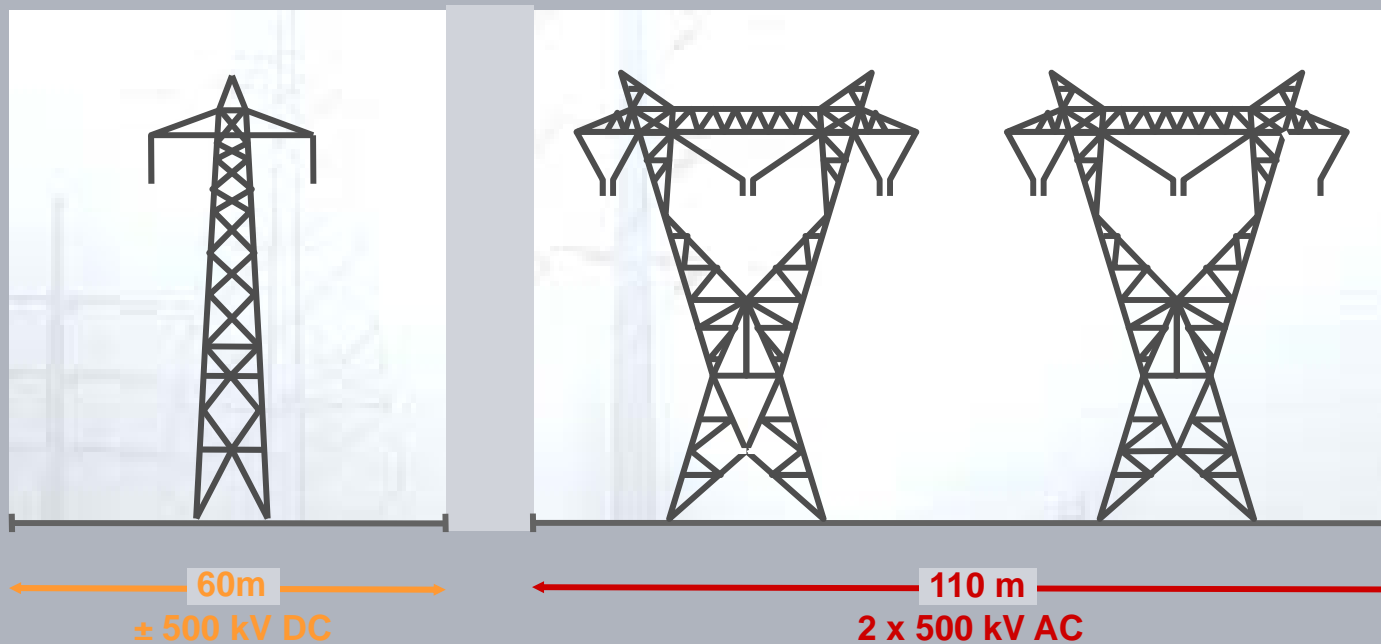

## Comparison of Losses-Case Study

Parameter	HVDC System	AC System
Voltage	±500 kV	400kV (1D/C+1S/C)
Power	2250 MW	2250 MW
Line Configuration	Quad Bersimis	Quad Moose
Line Length	970 km	970 km
Losses	135 MW (inc terminal losses)	216 MW
Capitalisation of diff with 97% Availability and 60% utilisation); tariff @10 cents	<b>USD 41 million</b>	

# Technical Considerations

## ■ Typical HVDC Short-Time Overload Characteristics

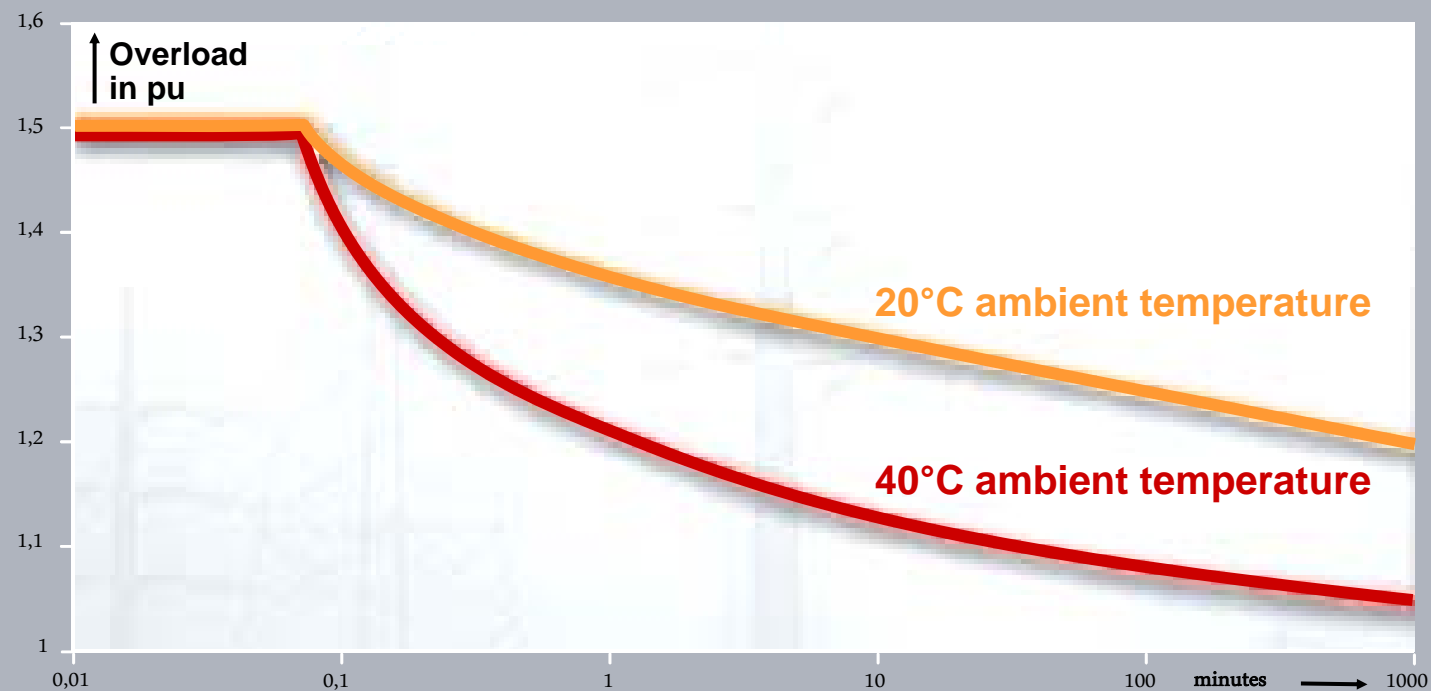

# Technical Considerations

## Inherent Continuous HVDC Overload vs. Ambient Temperature

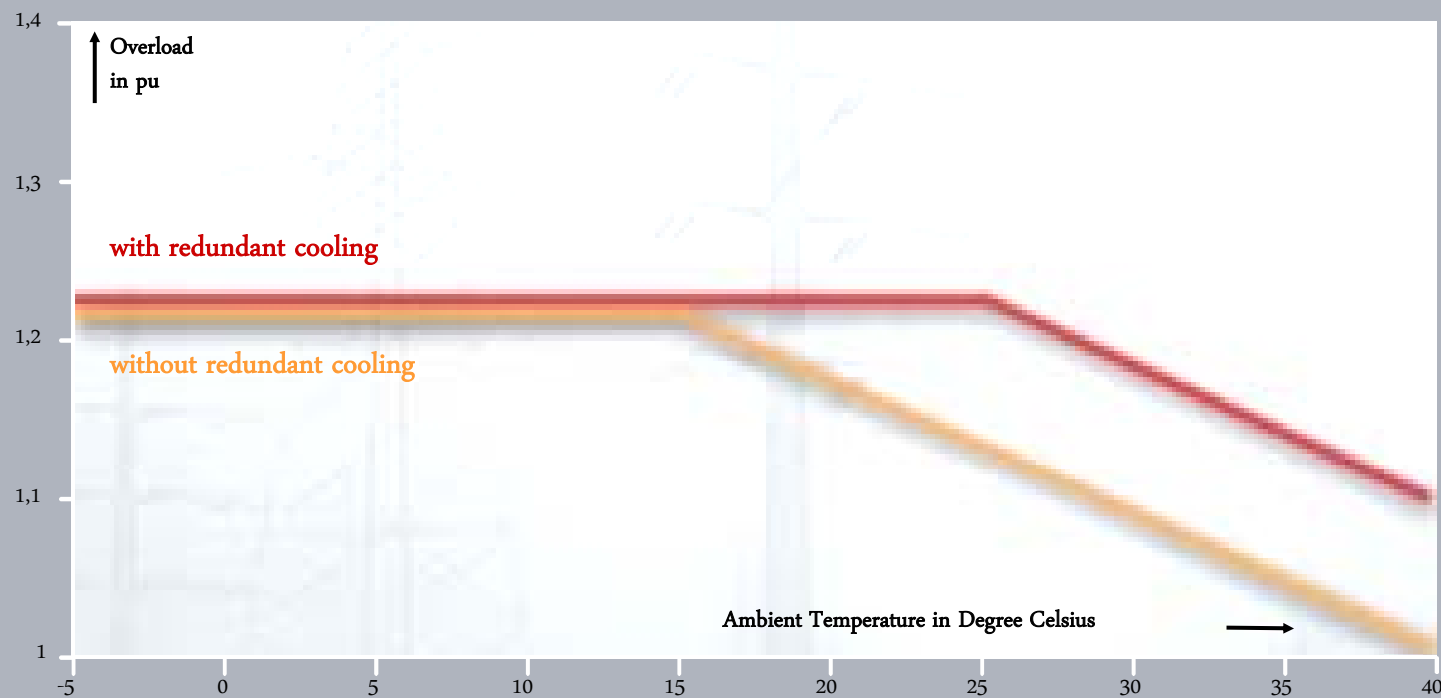

# HVDC Long Distance Transmission Systems

SIEMENS

## Monopolar

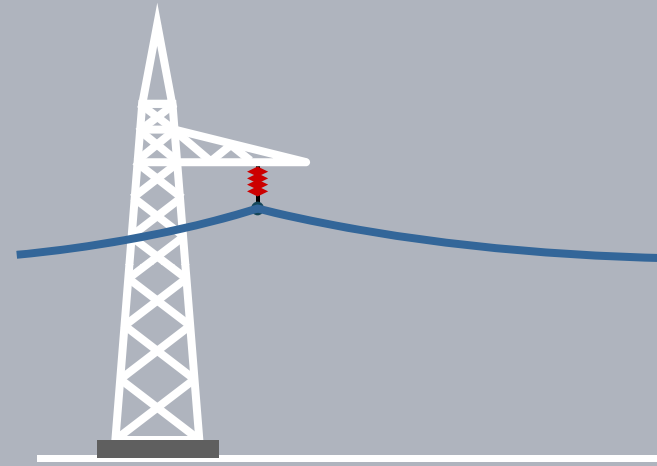
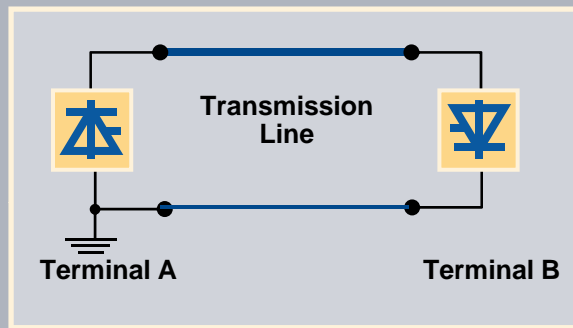

## Bipolar

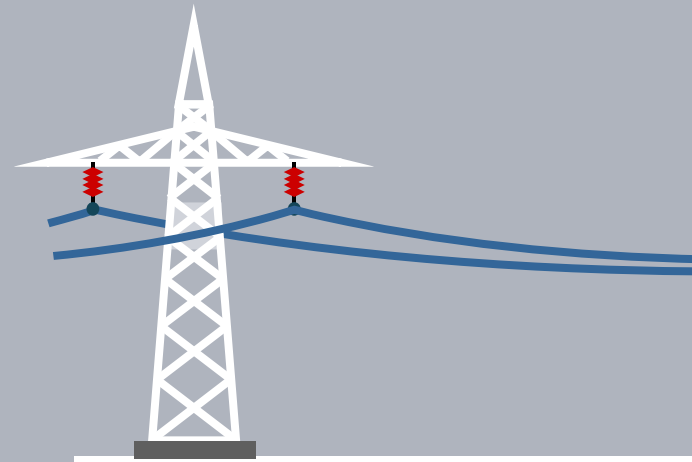
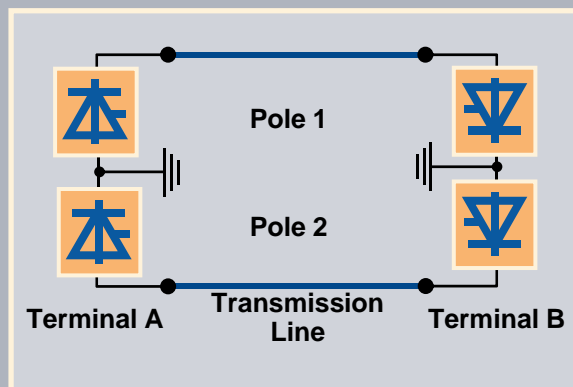

# HVDC Cable Transmission Systems

## ■ HVDC Classic Bipole

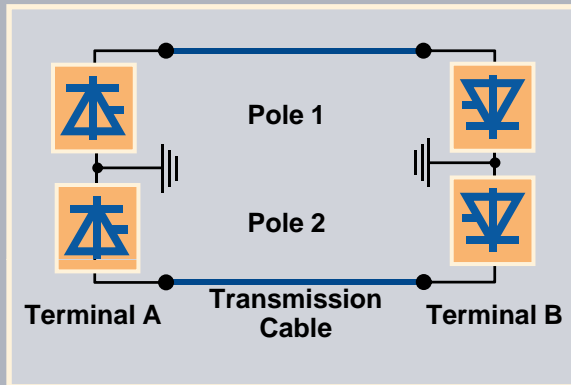

## ■ HVDC PLUS Symmetrical Monopole

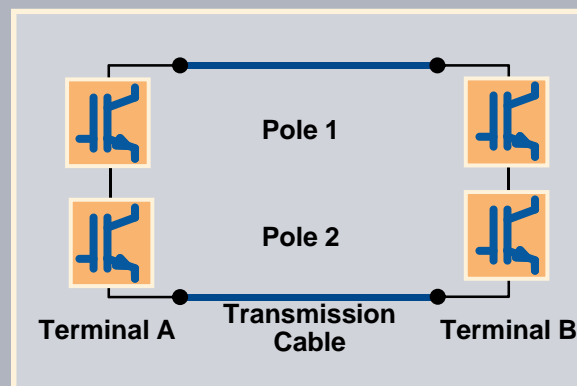

### Cable Systems

- Submarine Cable Systems
- Land Cable Systems

# HVDC Back-to-Back Links

## ■ Back-to-Back

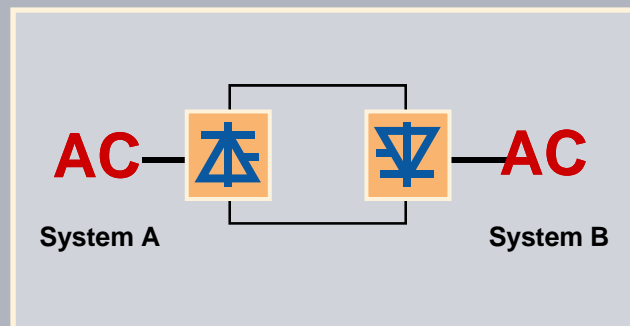

## Technical Reasons

- Different System Frequencies ( $f_1 \neq f_2$ )
- Different System Controls ( $\Delta f_1 \neq \Delta f_2$ )
- Exchange of low Power compared to the Size of the interconnected AC Systems
- Prevention of cascading Disturbances (“Firewall”)

# HVDC Long Distance Transmission Systems

## Multi Terminal

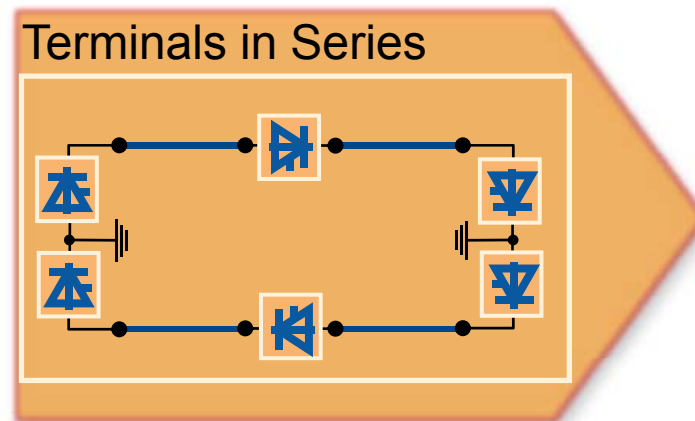
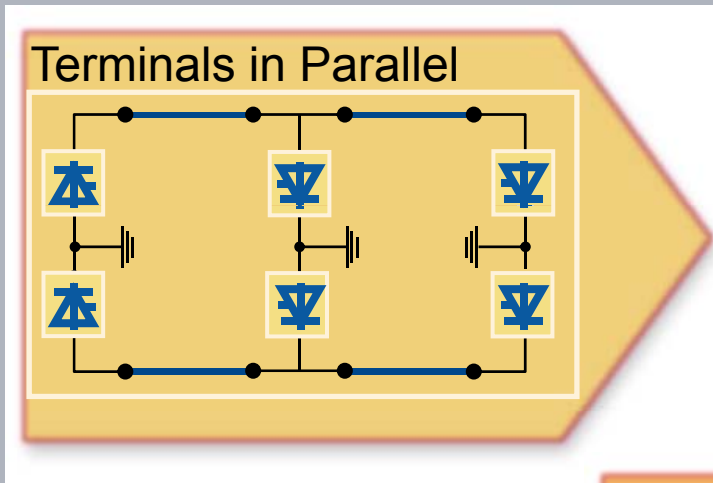

# FUNDAMENTAL OF HVDC OPERATION

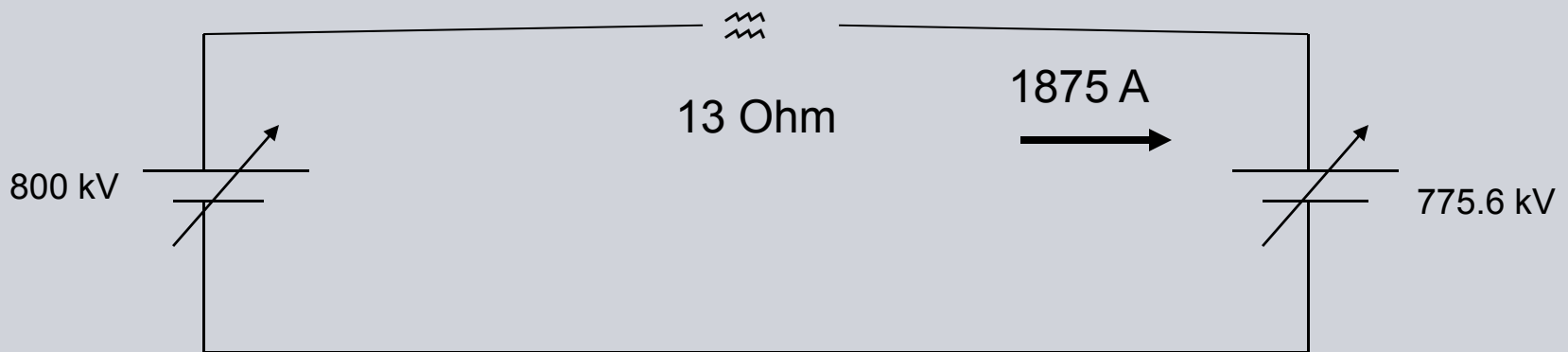
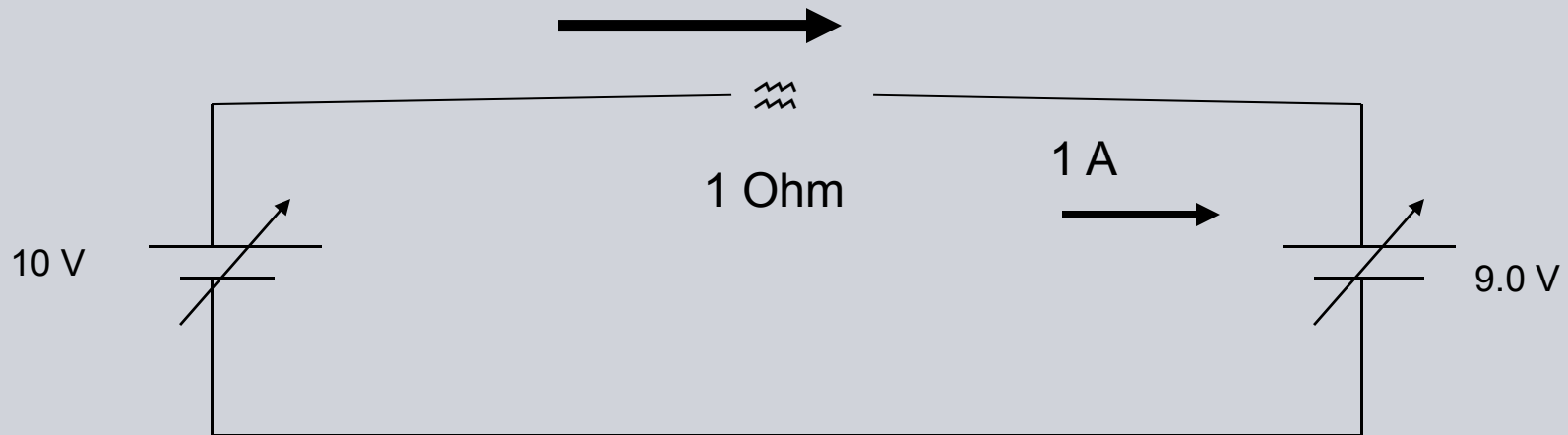
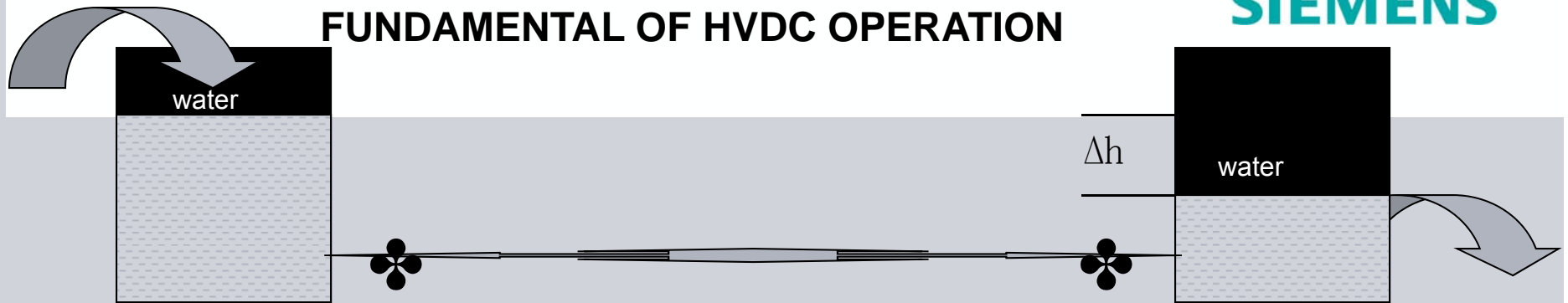

# Basic HVDC Single Line Diagram

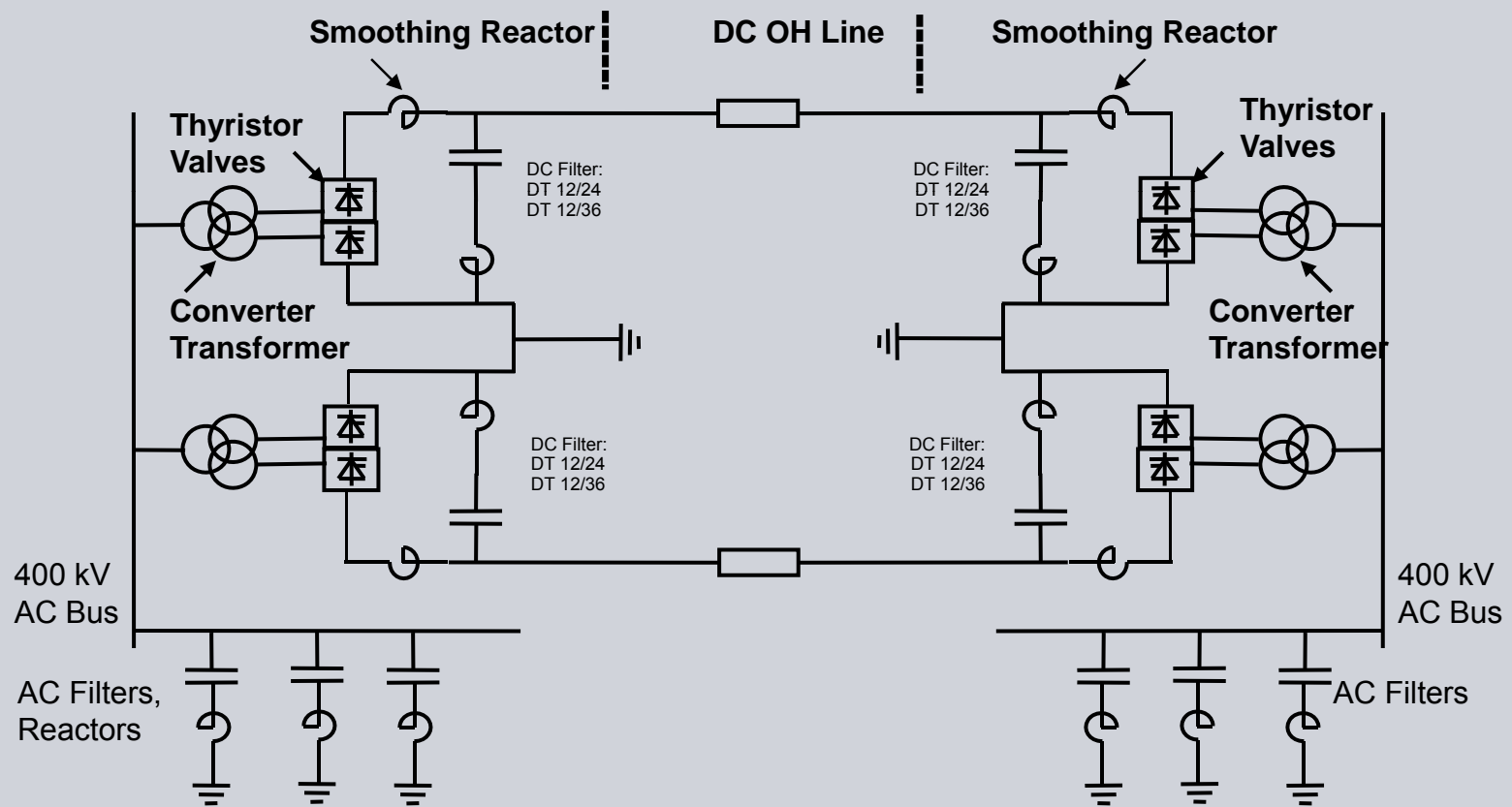

# Modes of Operation

SIEMENS

## Bipolar

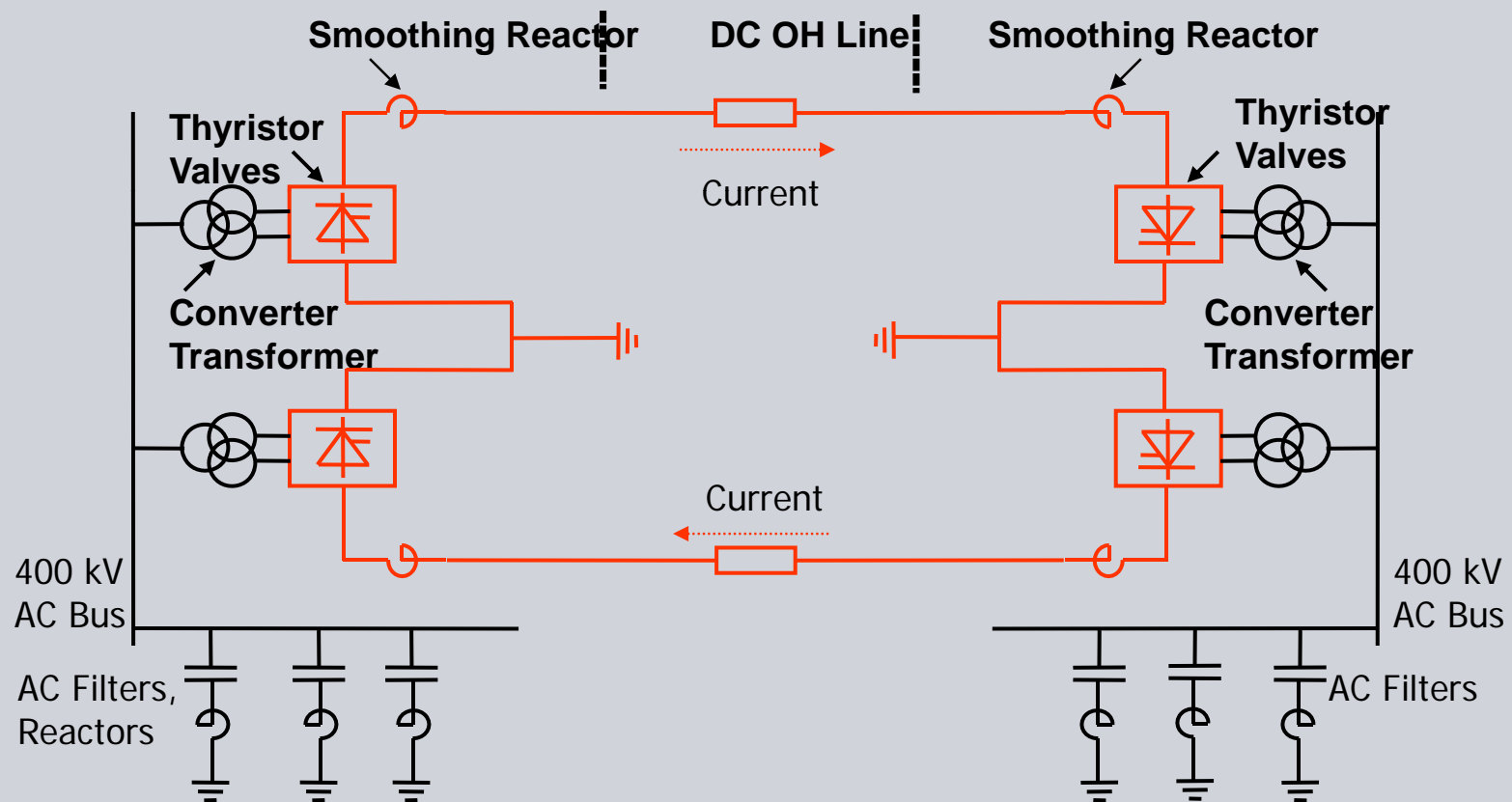

# Modes of Operation

SIEMENS

## Monopolar Metallic Return

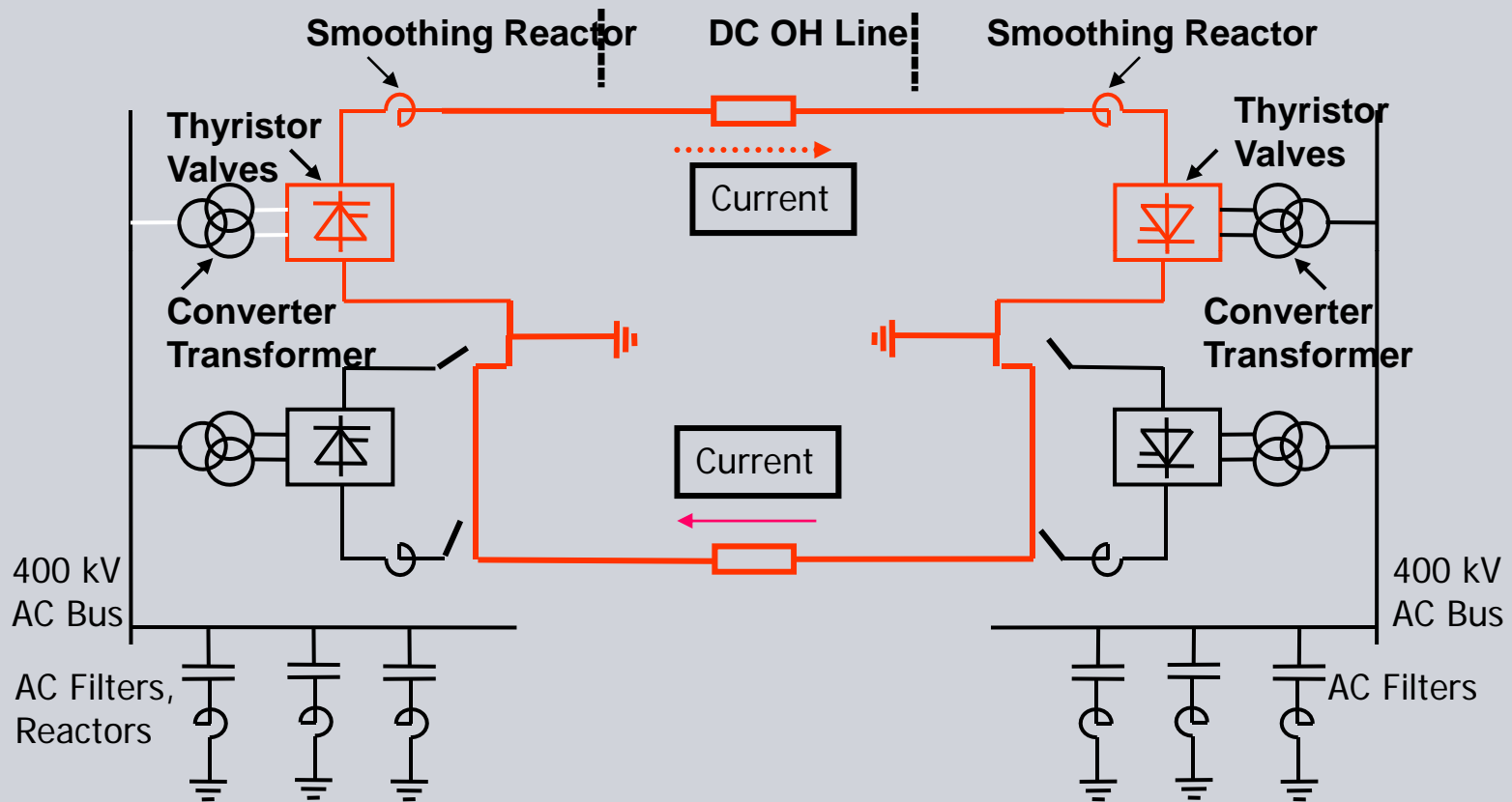

# Modes of Operation

SIEMENS

## Monopolar Metallic Return

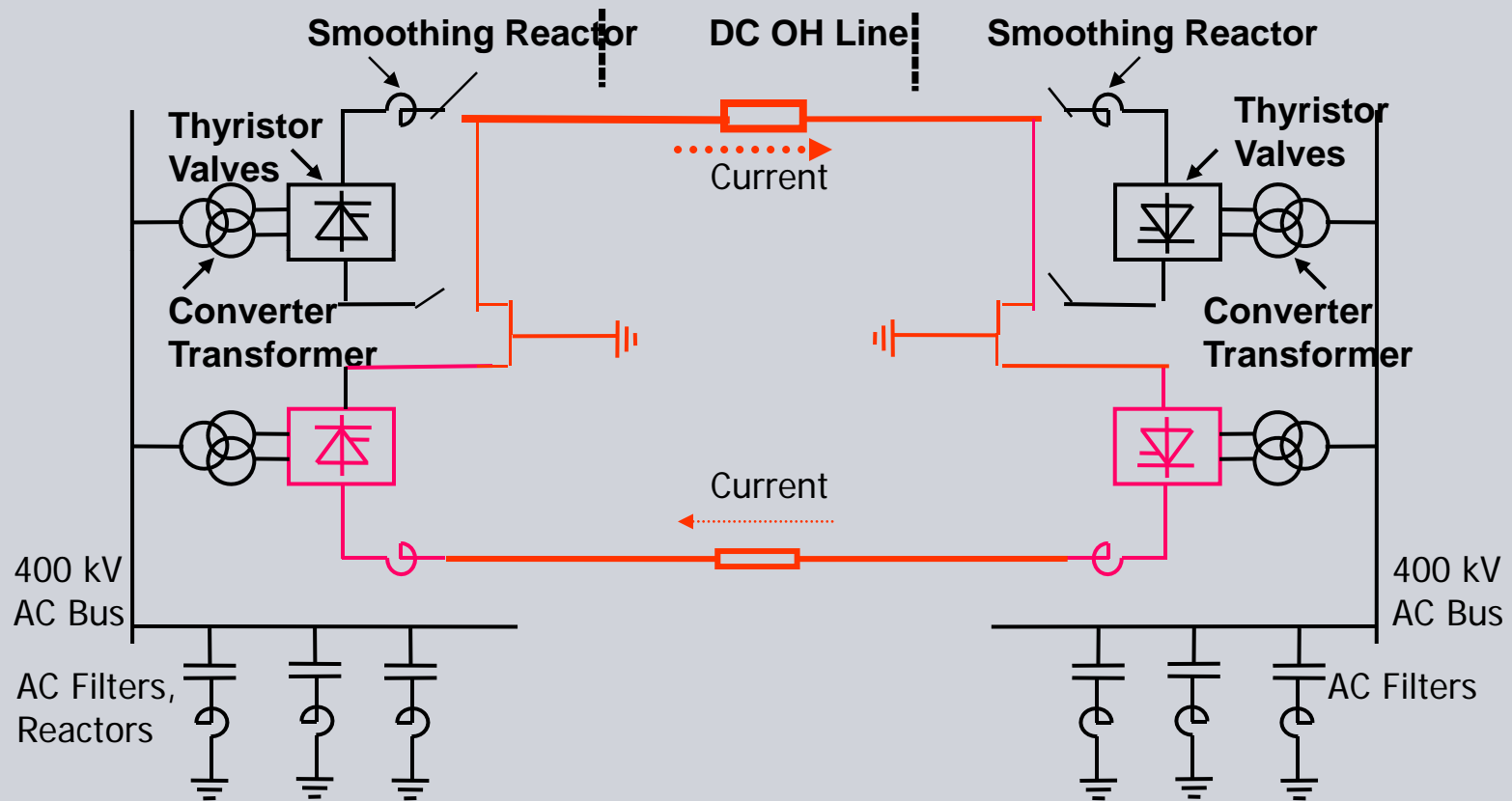

# Modes of Operation

SIEMENS

## Monopolar Ground Return

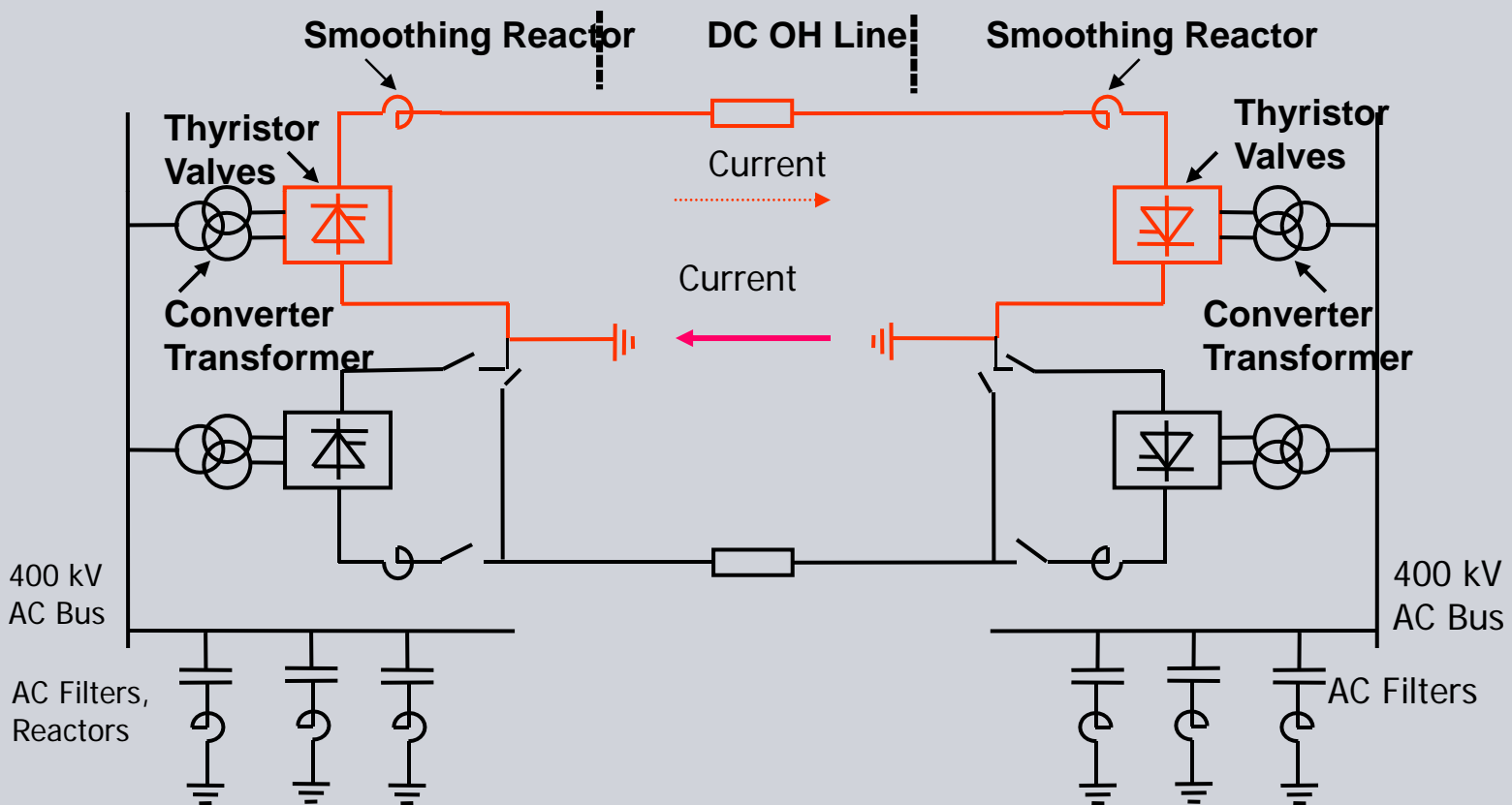

# Overall Layout of HVDC station

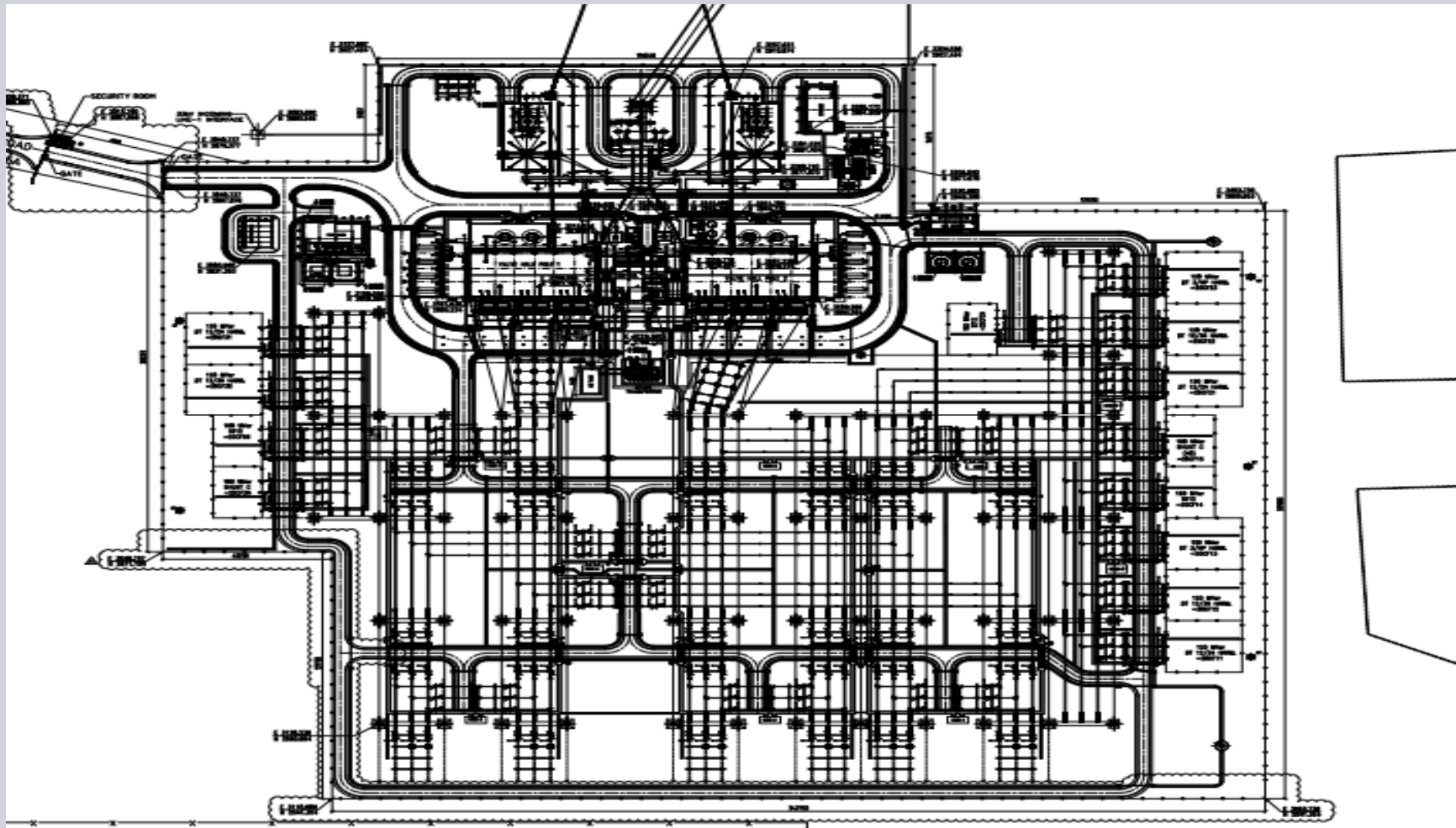

# Converter Island

SIEMENS

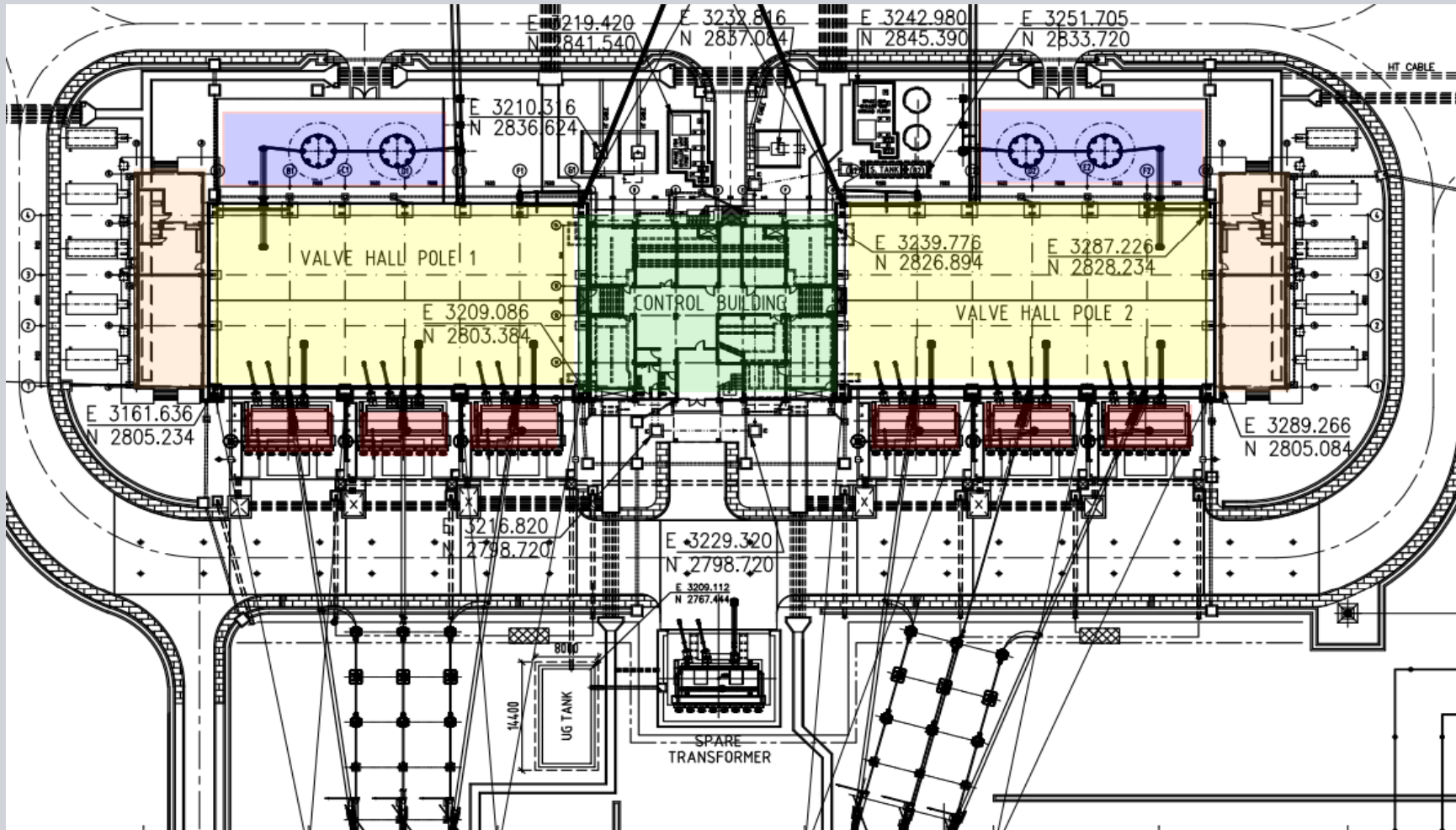

# Isometric view – Conventional Bipolar HVDC

SIEMENS

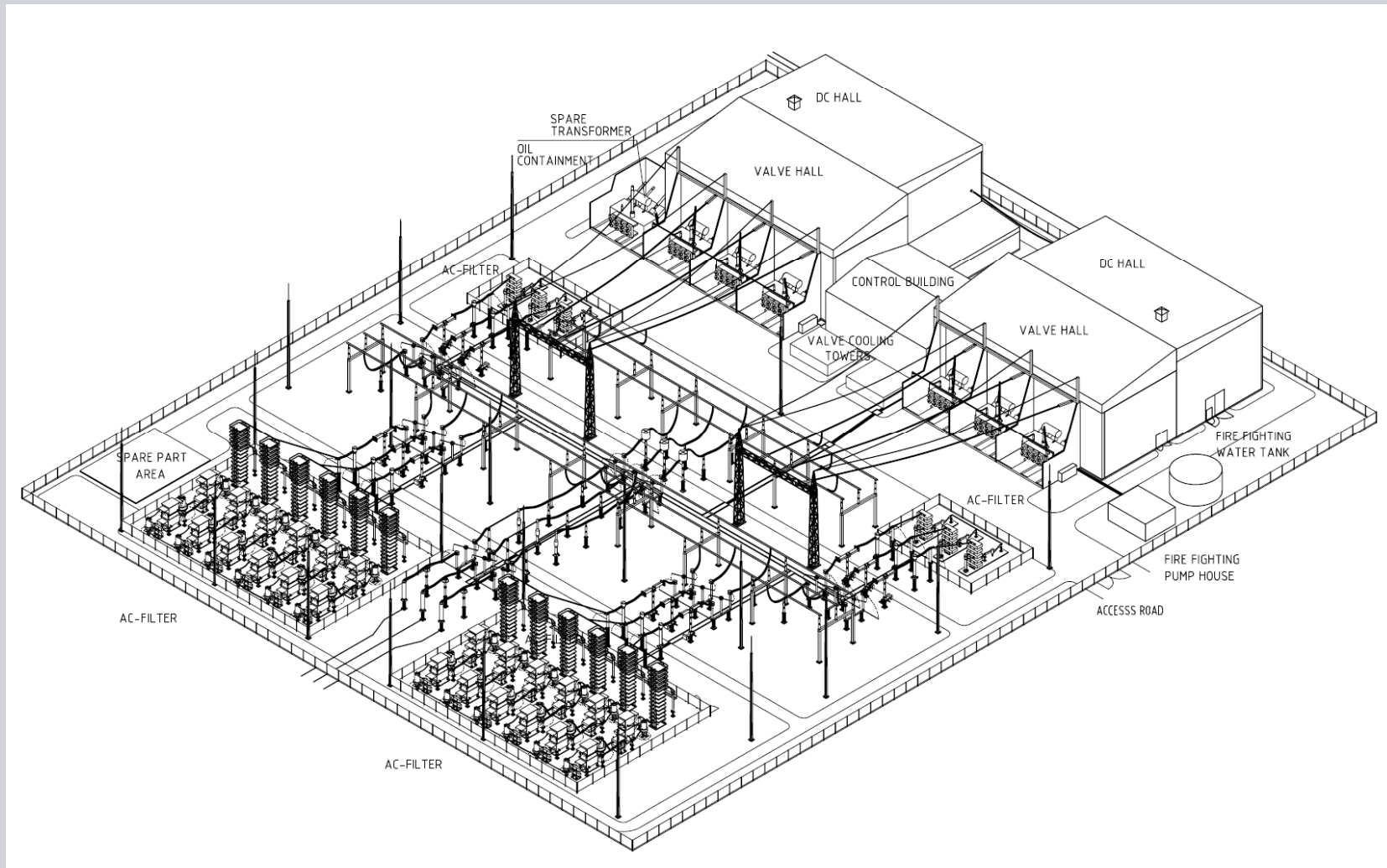

# Example HVDC “Classic”



# Key Components of HVDC Bipolar HVDC Terminal

SIEMENS

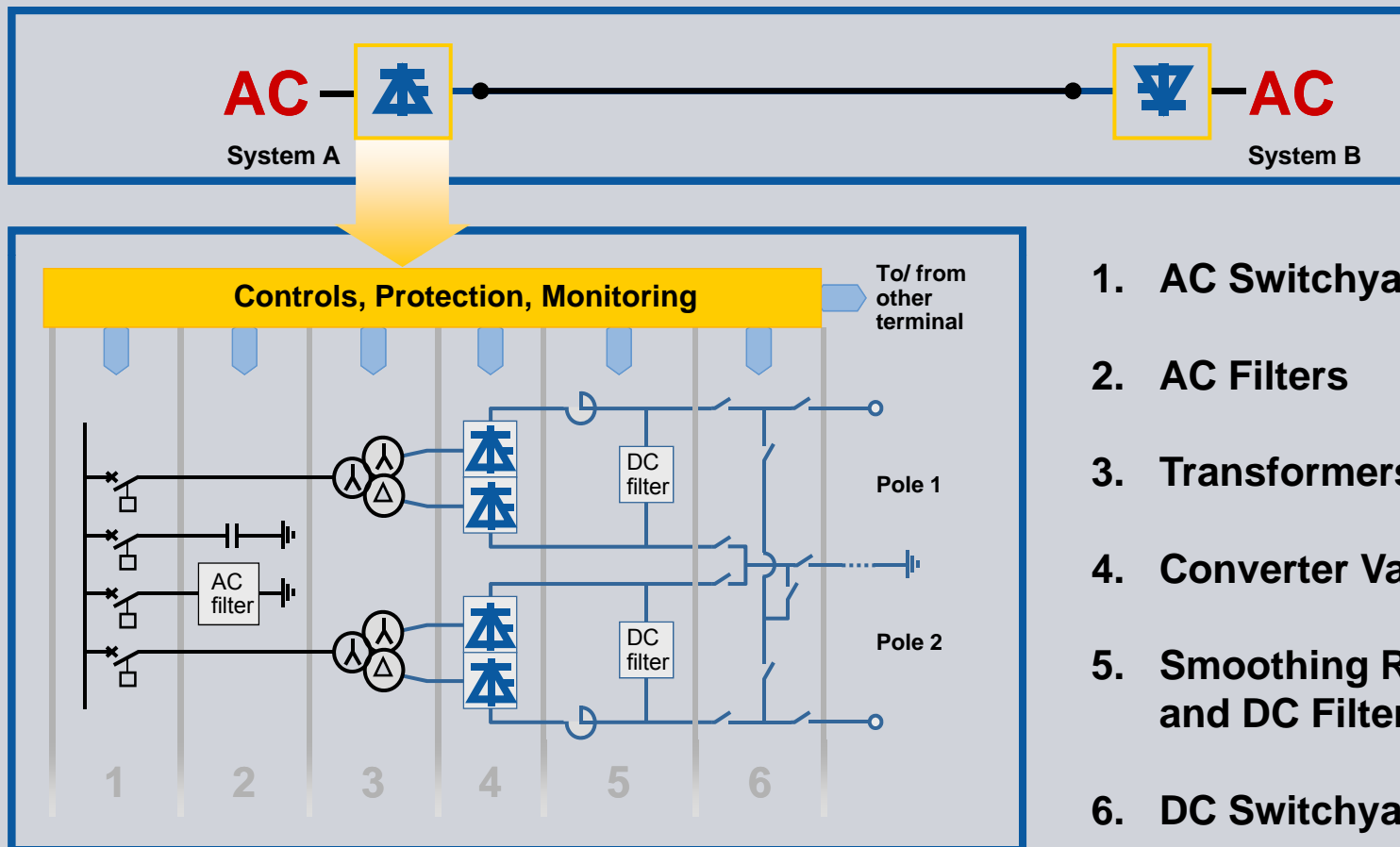

# HVDC Terminal Requirements

## **AC Switchyard**

Connects the Terminal to the AC System

## **AC Filters, Capacitor Banks**

Reactive Power Supply

Filter harmonic Currents

## **Converter Transformers**

Obtain the AC Voltage needed for the required DC Voltage

Obtain 12-Pulse Operation (Star and Delta Connection)

Allow for Series Connection of 6-Pulse Bridges

# HVDC Terminal Requirements

## **Thyristor Valves**

Convert AC to DC and vice-versa

Connect 6-Pulse Bridges in Series for required DC Voltage

## **Smoothing Reactors and DC Filters**

Smoothen the DC Current

Avoid Resonance with DC Line

Limit Interference caused by DC Side Harmonics

## **DC Switchyard**

Achieve required DC Side Transmission Configuration

# Main Equipments

- Thyristor Valves
- Valve Cooling
- Converter Transformer
- Smoothing Reactor
- DC Switches
- AC Filters
- DC Filters
- PLC Filter
- Ground Electrode

# Thyristor Valves

- The rectification and inversion process is carried out by the thyristor valves
- Housed inside the valve halls

# Thyristors

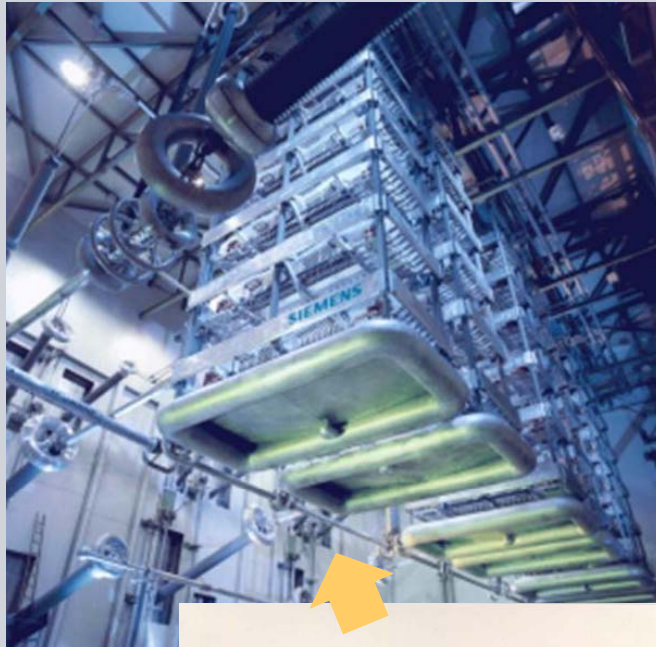

- Thyristor Technology with direct Light-Triggered Thyristors
- Rated Voltage up to 800 kV
- Rated Current more than 3,000 A
- Free from Oil and exclusive Use of Flame-retardant self-extinguishing Materials ⇒ Reduced Fire-Hazard
- Efficient and Corrosion-free Water Cooling
- Excellent Seismic Performance

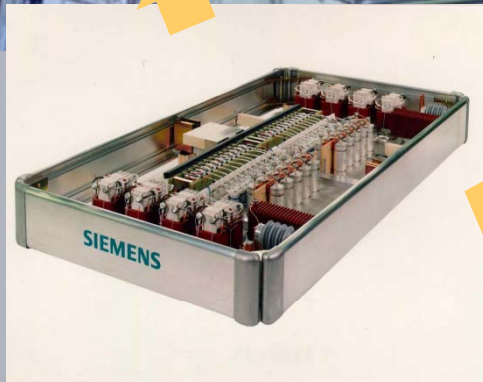

Thyristor



# Direct Light Triggered Thyristor LTT

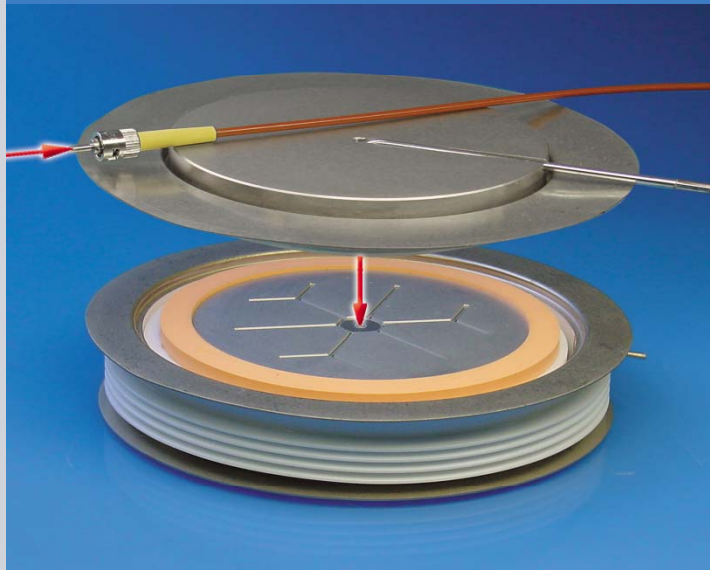
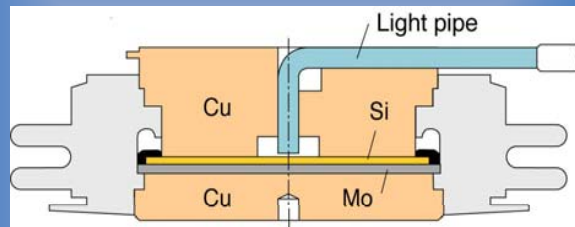

## High Reliability

- 80 % less Electronic Components
- Direct Laser Light-triggered Thyristor
- Thyristor Blocking Voltage: 8 kV
- Thyristor Wafers:
  - 4" for currents up to 2,200 A
  - 5" for currents up to 3,700 A

# Comparison of Electrical with Direct Light Triggering

**ETT**  
 Triggering and Monitoring  
 Functions

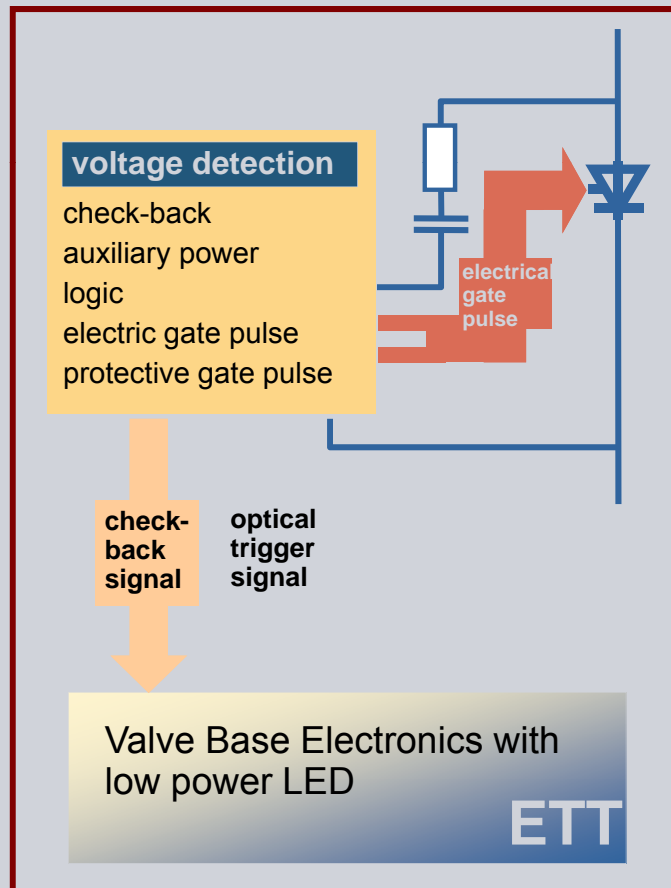

**LTT**  
 Firing and Monitoring System conveniently  
 from the Ground to Thyristor Potential

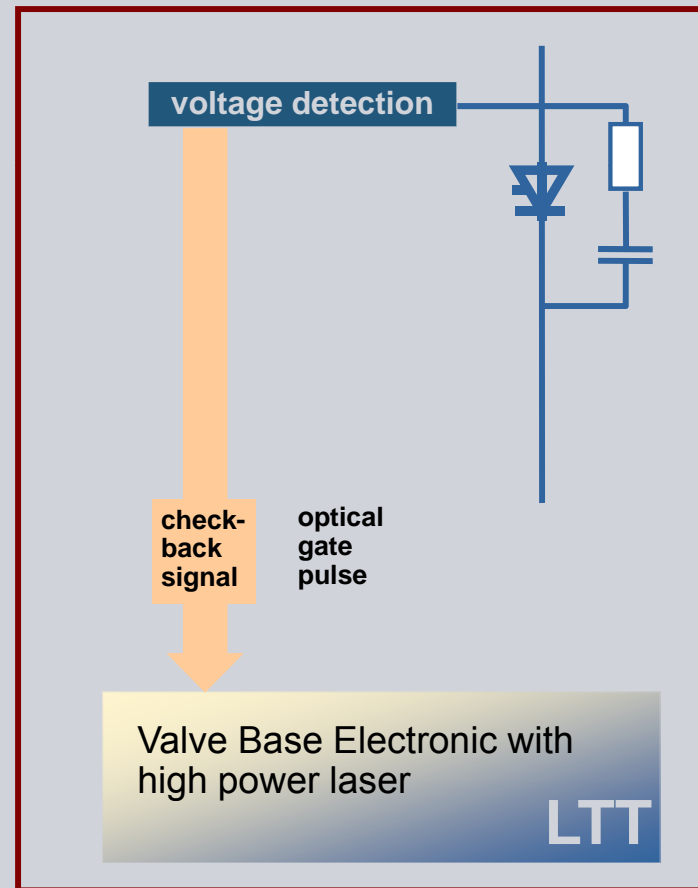

# Parallel Water Cooling

The Siemens Design of the Valve-Cooling Circuit with **Parallel-Water Cooling** has been in Operation for more than 30 Years



- It provides all thyristors with the same cooling water temperature
- Electrolytic currents are minimized by the use of grading electrodes
- Careful choice of materials allows operation without de-oxygenizing equipment
- None of these systems had corrosion problems

a Thyristor  
b Heat Sink  
c Piping  
d Manifold



# Thyristor Valves-PEB Building



# Valve hall

SIEMENS



# Valve hall

SIEMENS



## Thyristors Valves - Module Layout

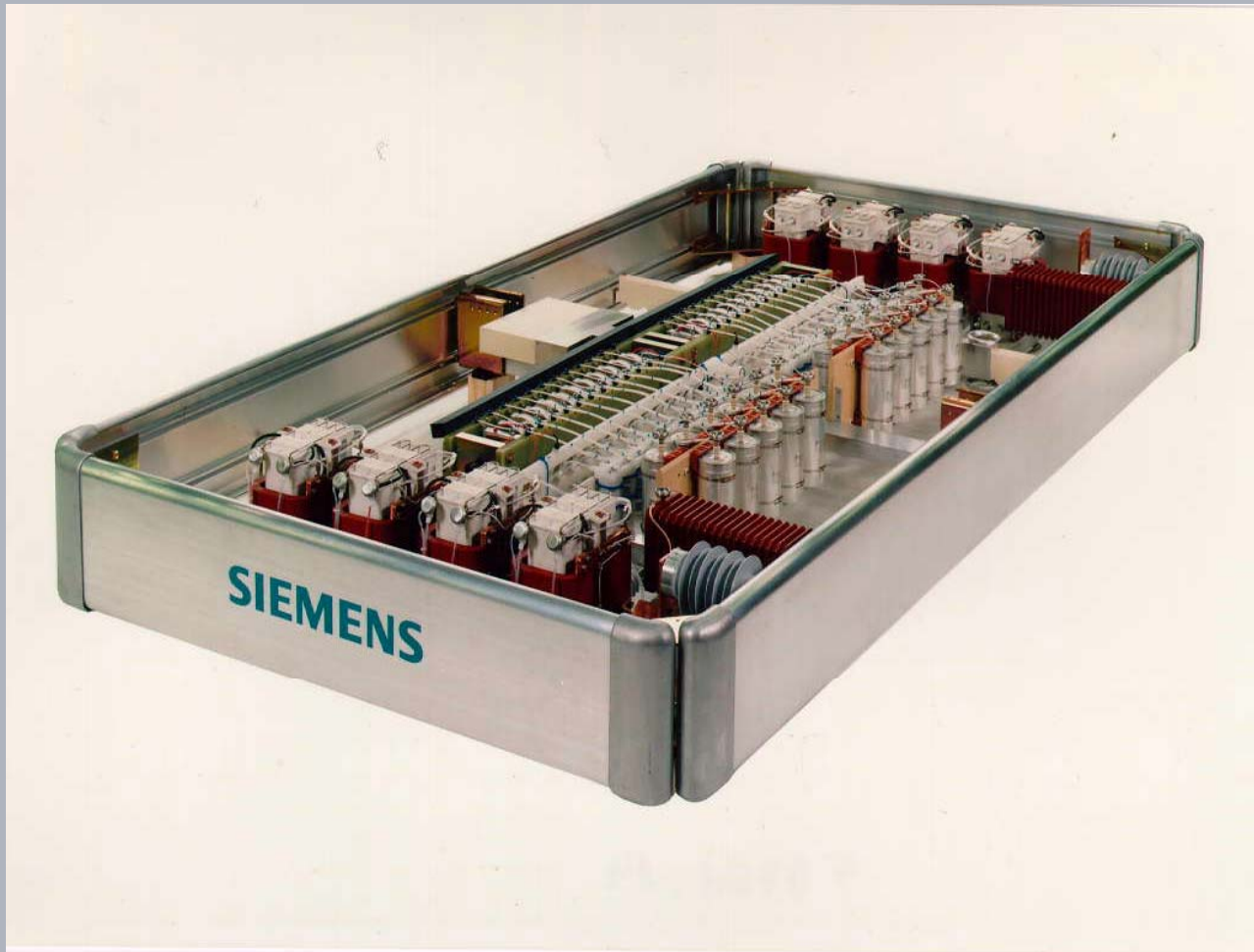

# Simplified Cooling Circuit

SIEMENS

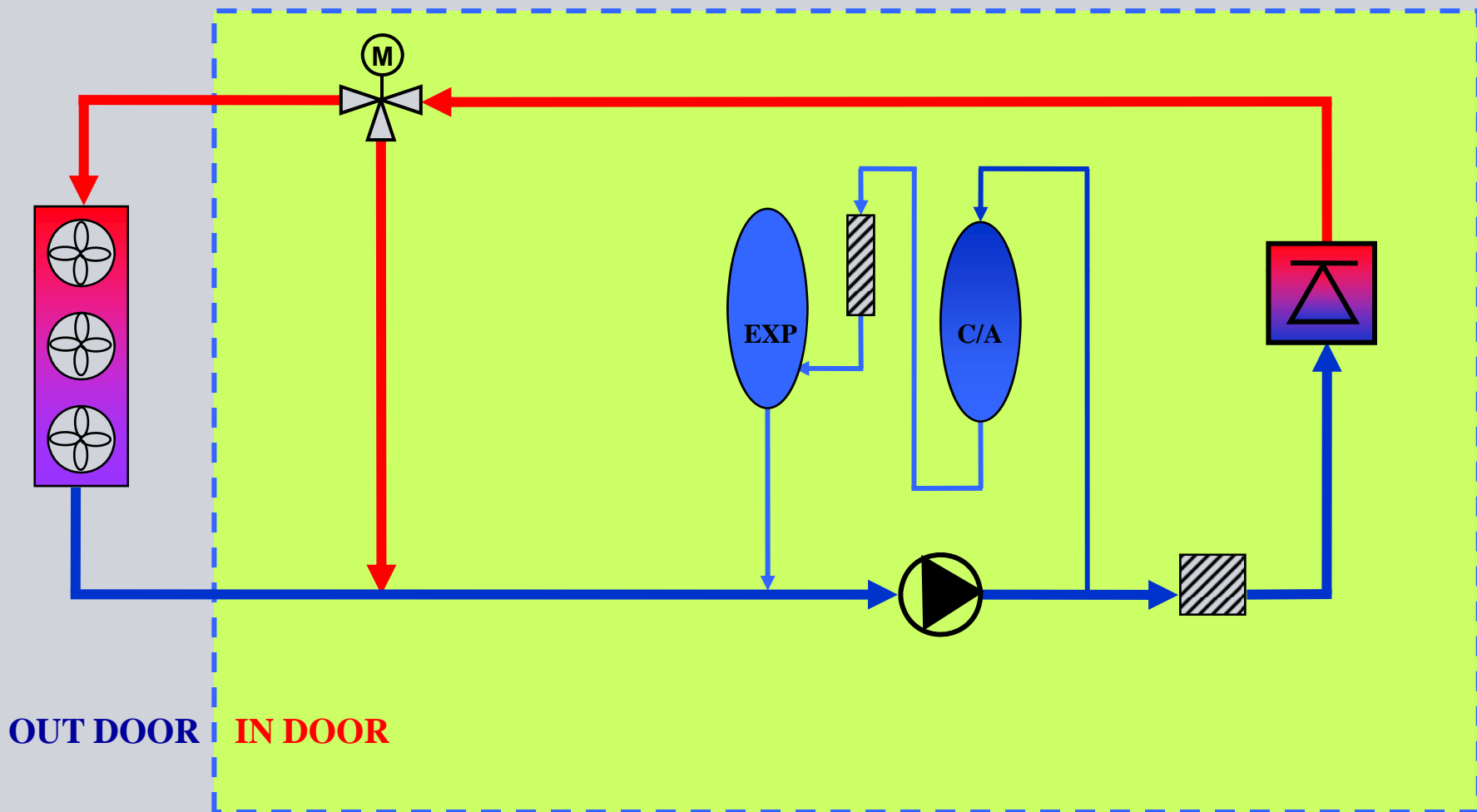

# Air Blast Cooler

SIEMENS

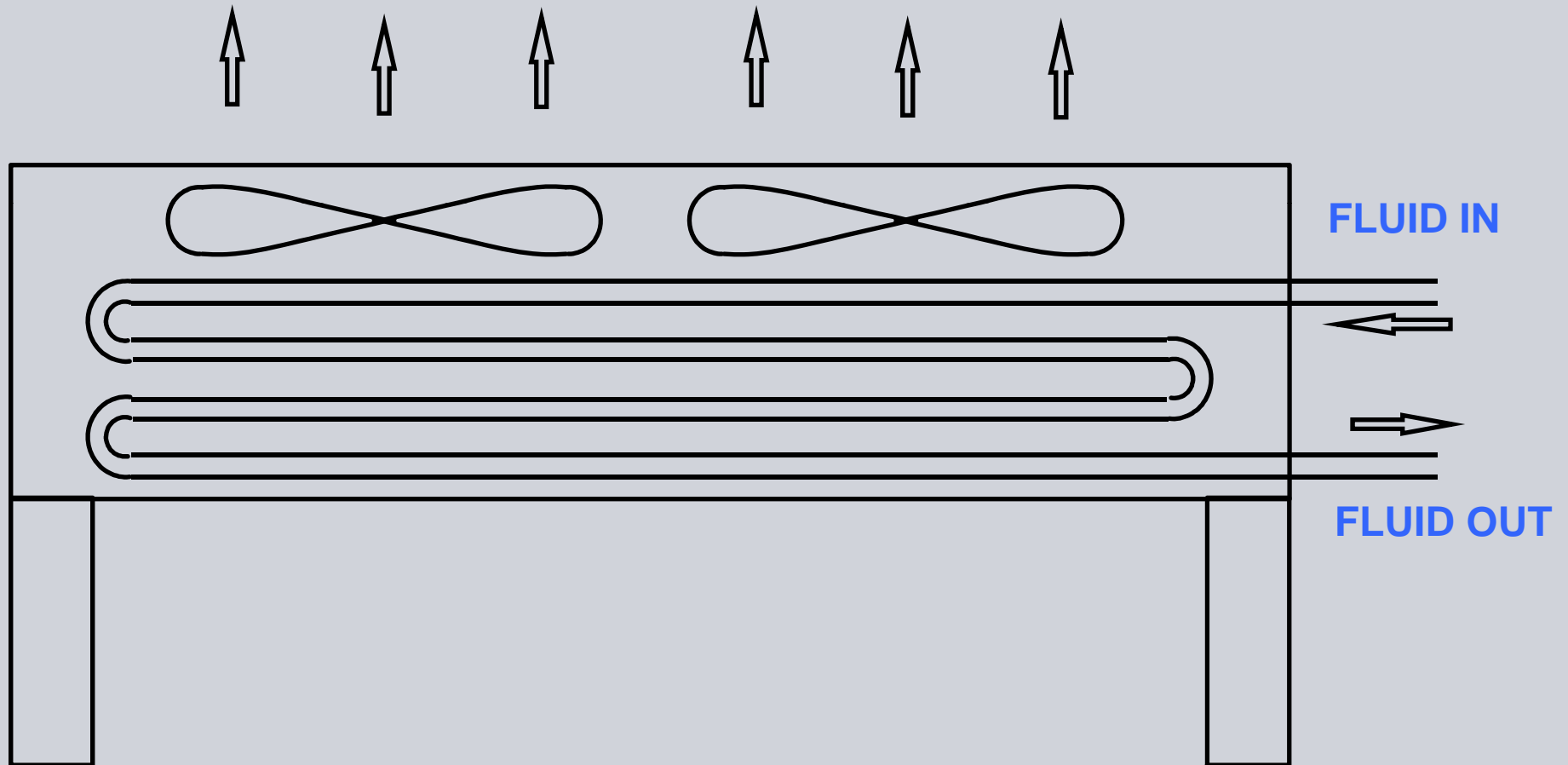

# Valve Hall-External View

SIEMENS



# East-South Interconnector II, India, 2003

**SIEMENS**



# Converter Transformer

- Provide the AC voltage for the converter
- Subject to DC voltage and currents on the Valve side.
- Can be two winding or three winding depending on MVA rating and size
- Subject to special tests such as DC withstand, polarity reversal and heat run test with harmonic currents taken into account

# Winding Arrangement

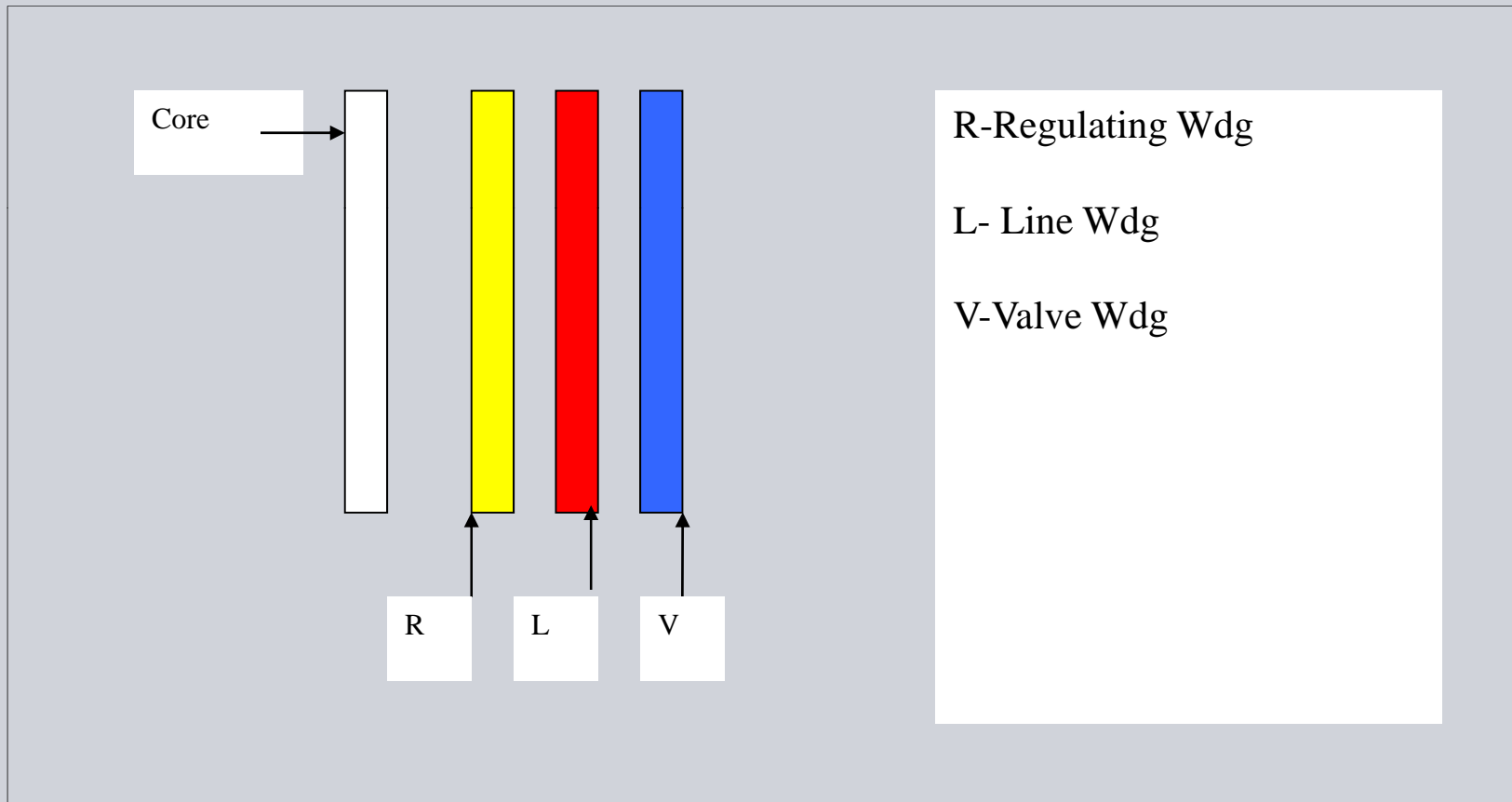

# Winding arrangement

SIEMENS

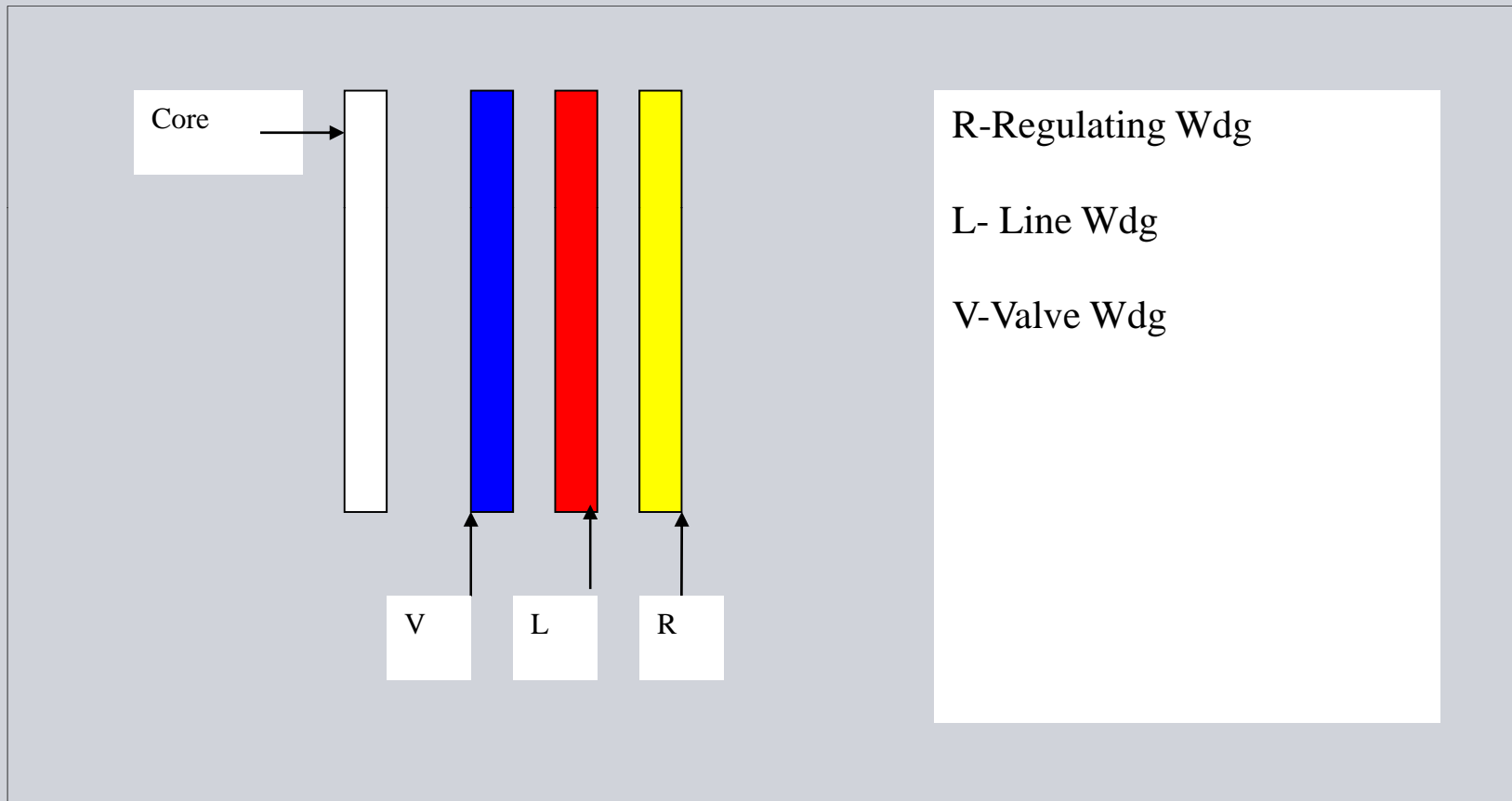

# Converter Transformer

SIEMENS



# Converter Transformer

SIEMENS



# Converter Transformers



**400 MVA 1-ph / 3-w**



**354 MVA 1-ph / 3-w**

# Smoothing Reactor

- Removes ripples from DC voltage
- Limits rate of rise of current in case of DC line faults
- Limits higher order harmonics in DC line
- Limits possible resonance at fundamental and 2<sup>nd</sup> harmonic frequencies

# HVDC Smoothing Reactor

## Oil immersed Design



**270 mH**  
**500 kV DC**  
**3,000 A**

## Air-Core Design



**150 mH**  
**500 kV DC**  
**1,800 A**

# Smoothing Reactor

SIEMENS



Inductance	250 mH (two coils @ 125 mH)
Rated voltage	500 kV dc
Rated current	2000 A dc

# Siemens HVDC Transmission Supplies in India

**SIEMENS**

**Converter Transformer and Valve Hall –  
Talcher Station (ESI - II)**



**AC Harmonic Filters – Talcher Station (ESI - II)**



## High Speed DC Switches

**Switches to commutate direct current  
(MRTB, MRS, HSNBS, HSGS)**

**Metallic Return Transfer Breaker (MRTB)  
and Metallic Return Switch (MRS)**

**Use of standard SF<sub>6</sub> circuit breakers**

# MRTB & GRTS

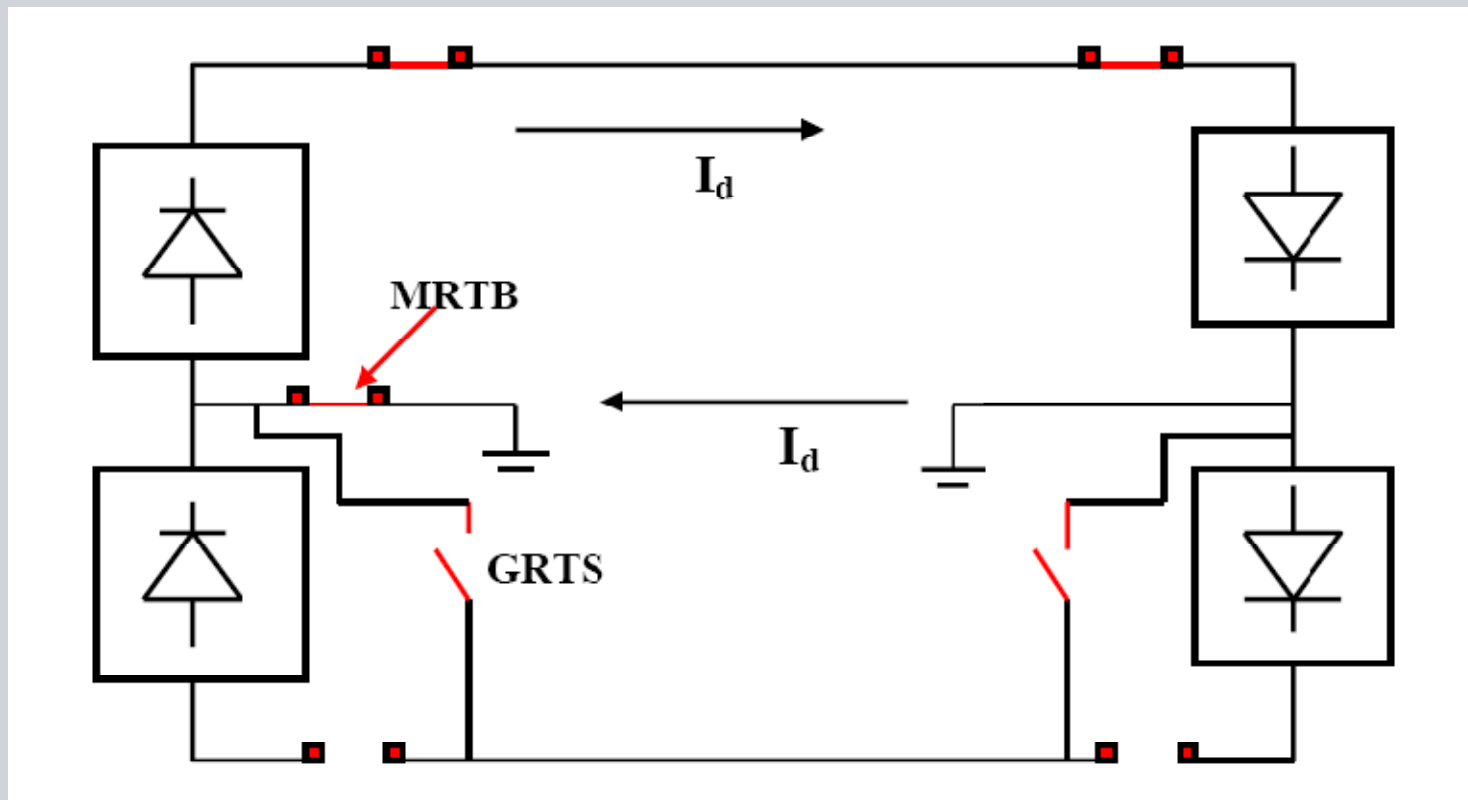

# MRTB & GRTS

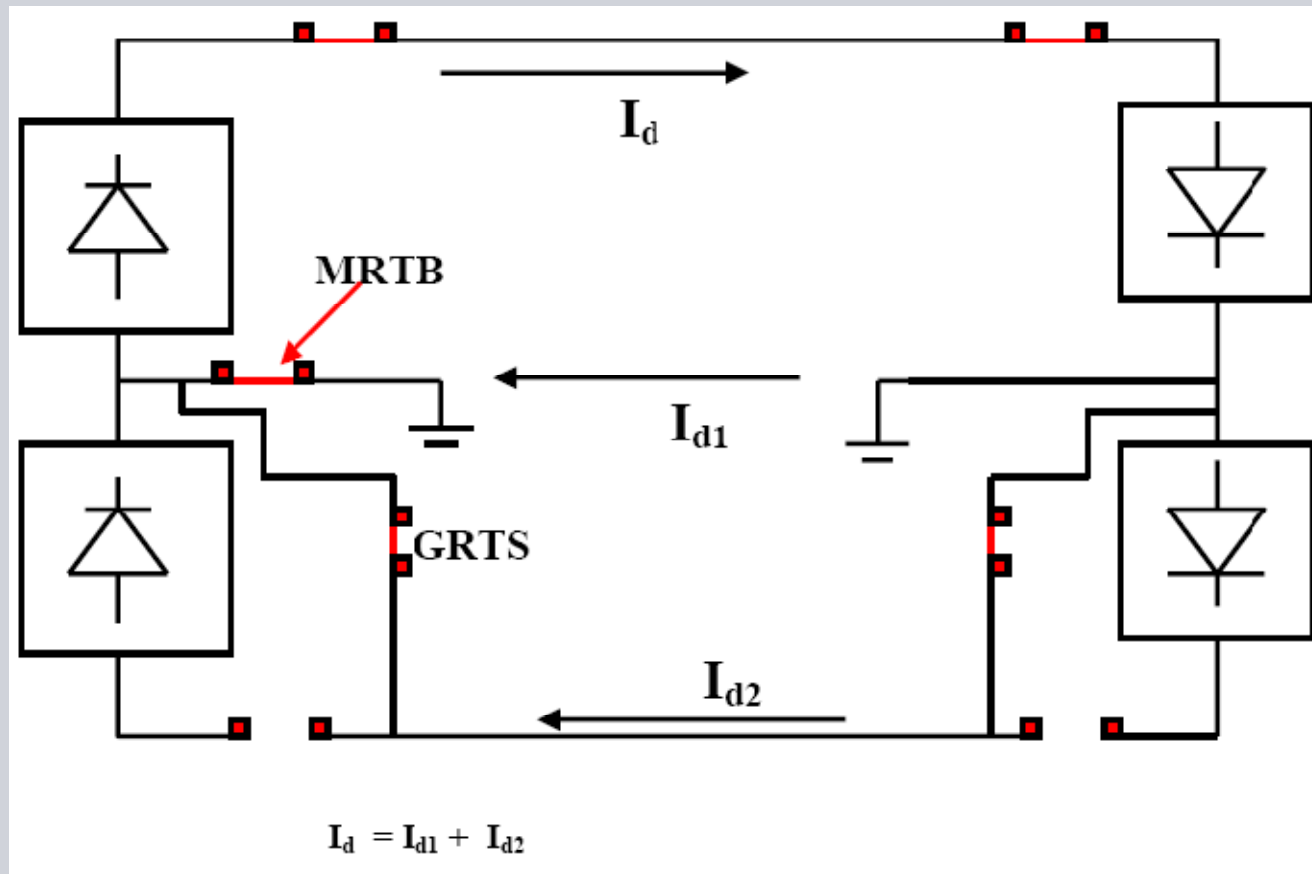

# MRTB & GRTS

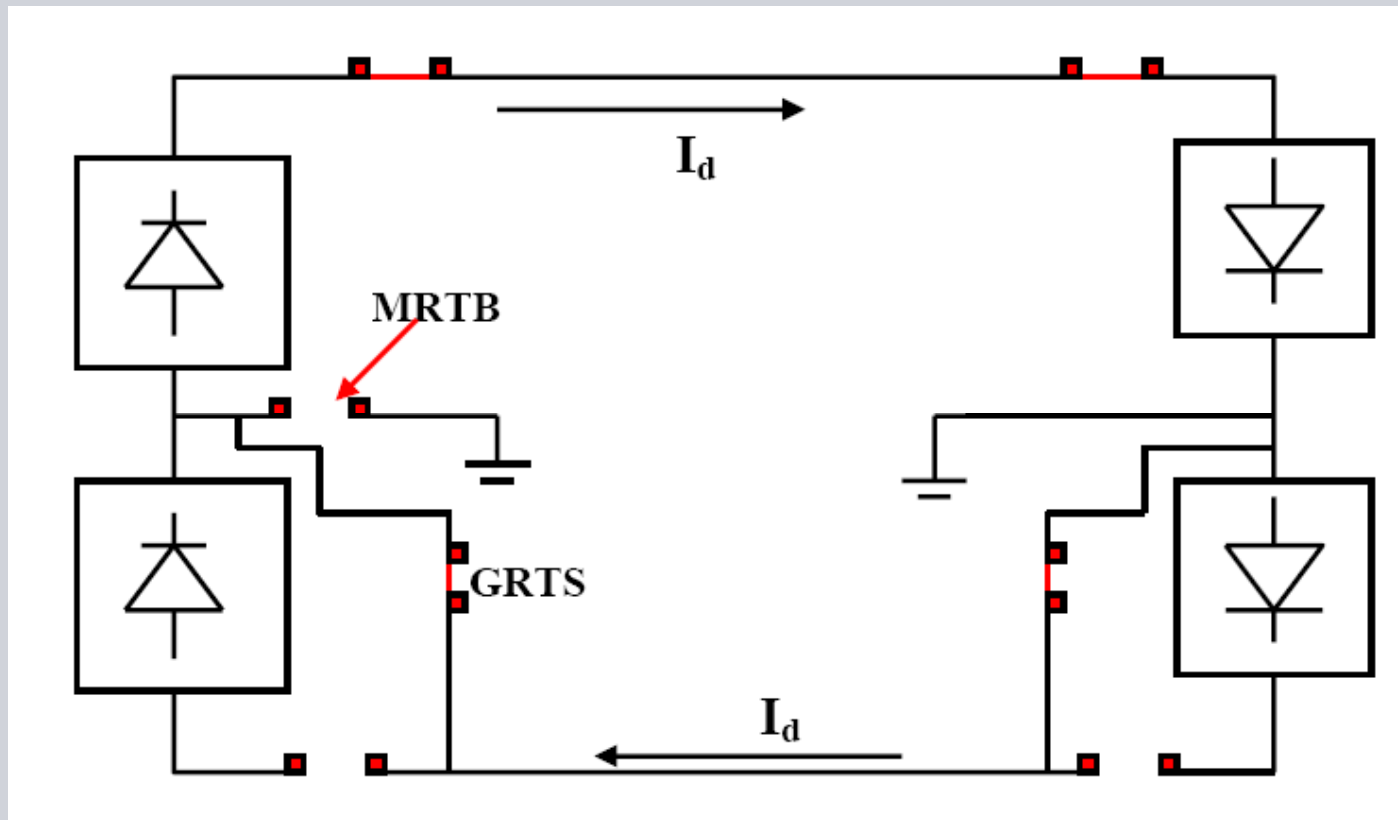

# Operation of MRTB

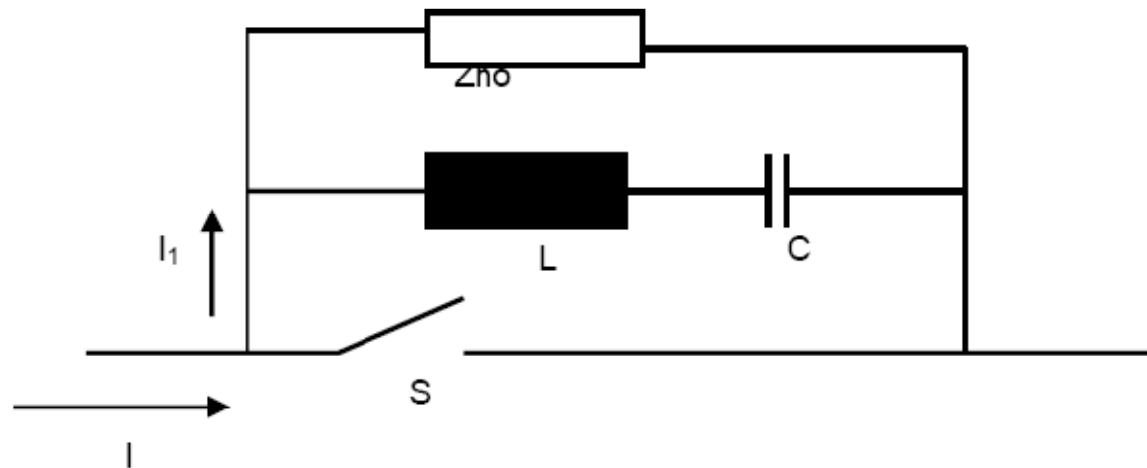

Operation of the MRTB is as follows:

1. As the contact S opens, and develops an arc voltage, it generates an oscillation in the circuit L,C, and S at the natural frequency of the loop which is known and part of the design.
2. As the current in S decreases by being shunted to the L and C branch, the arc voltage of S increases due to its negative current voltage characteristic.
3. A current oscillation is set in L and C which grows in magnitude with time until its magnitude equals the current to be interrupted creating a current zero in S allowing it to extinguish and recover.

# Bipolar and Monopolar metallic return is the normal mode of Operation

Why and when Ground Return ?

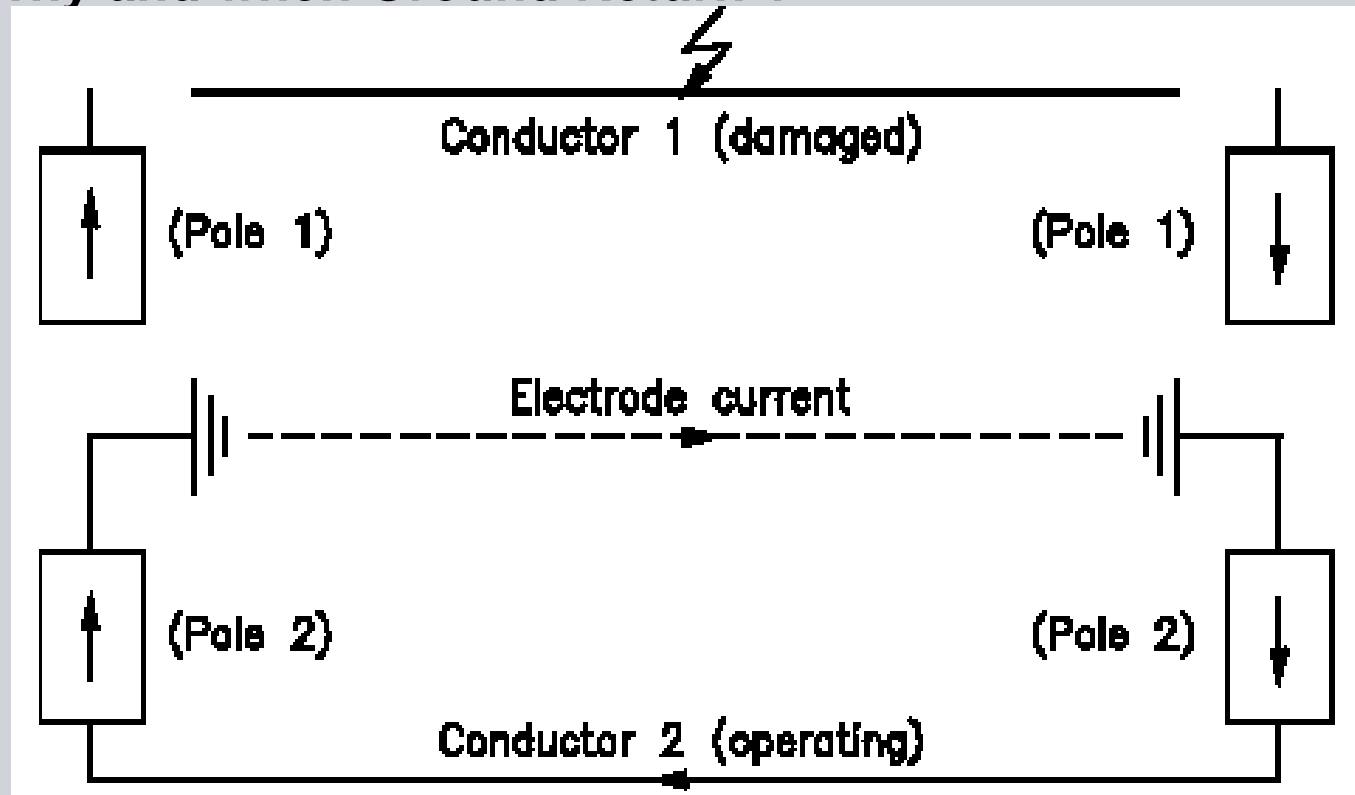

Permanent fault on one Pole conductors of DC line.  
 Scheduled maintenance for major work of DC line.

# TYPICAL LAYOUT OF ELECTRODE STATION

**SIEMENS**

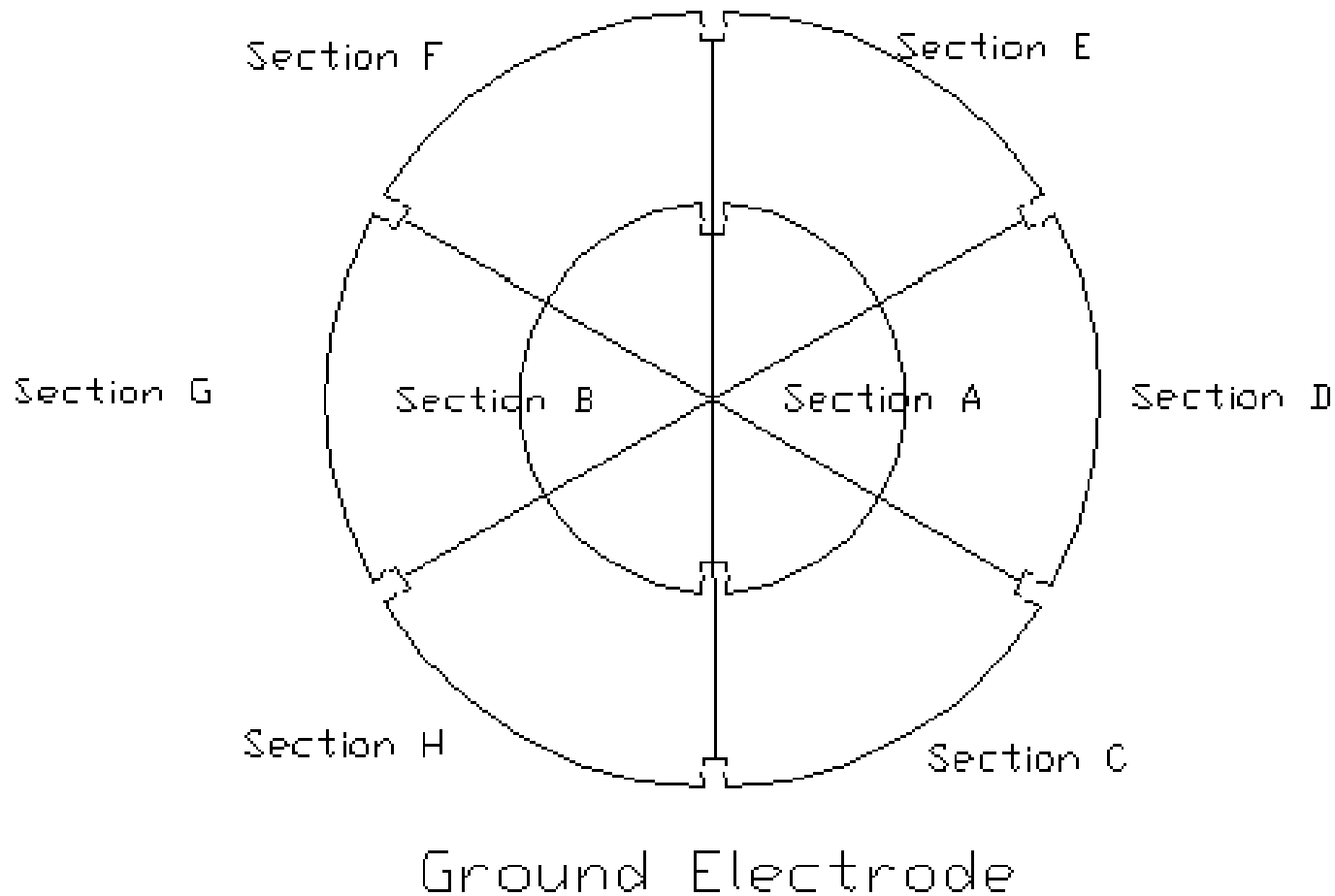

## Ground Electrodes Effects

- Local Effects( Upto  $< 1$  km)
- Safety of Humans and Animals
- High temperature rise of Ground and drying of soil.
- Remote Effects (may be upto 50 Km and beyond)
- Potential rise can cause DC current flow in transformer Neutrals
- Corrosion of buried metallic objects.

# Design Requirements

## Local Electrode parameters.

- ❖ Ground Electrode resistance  $\leq 0.3 \Omega$
- ❖ Touch Voltage  $\leq 40$  Volts
- ❖ Step Voltage  $\leq 6$  Volts
- ❖ Current Density  $\leq 0.5 \text{ A/m}^2$
- ❖ Temperature on the surface of sub-electrode:  $\leq 100^\circ \text{ C}$ .

## Remote Effects.

The Ground potential rise and electric field shall decay fast and shall be negligible (few Volts) within 15-20 kms of electrode site.

# DC Yard

**SIEMENS**



# DC Yard

SIEMENS

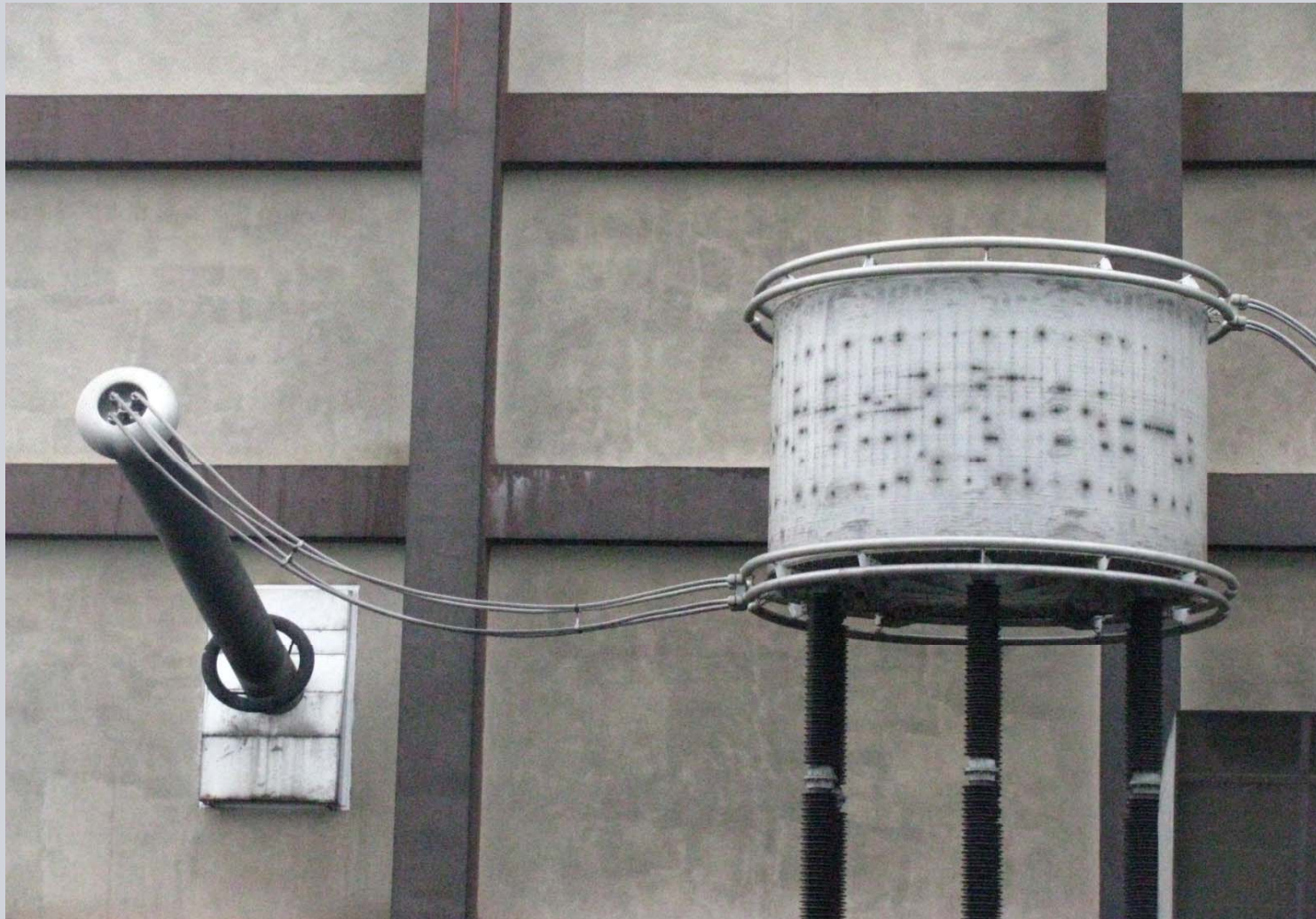

# Auxiliary Systems-HVDC

- Auxiliary Power
- LT Power System
- DG Set
- DC Power/UPS
- Air Conditioning/Ventilation
- Fire Fighting/Detection
- Illumination
- PA System
- Valve Cooling System
- Oil Filtration System
- Service Water
- Telephone & PA System

# Auxiliary Power Sources

- Usually two 33kV/11kV sources
- DG Set connected on LT bus
- Voltage Variation:  $\pm 10\%$
- Frequency Variation:  $\pm 5\%$

# Typical Aux Power Scheme for HVDC Station

SIEMENS

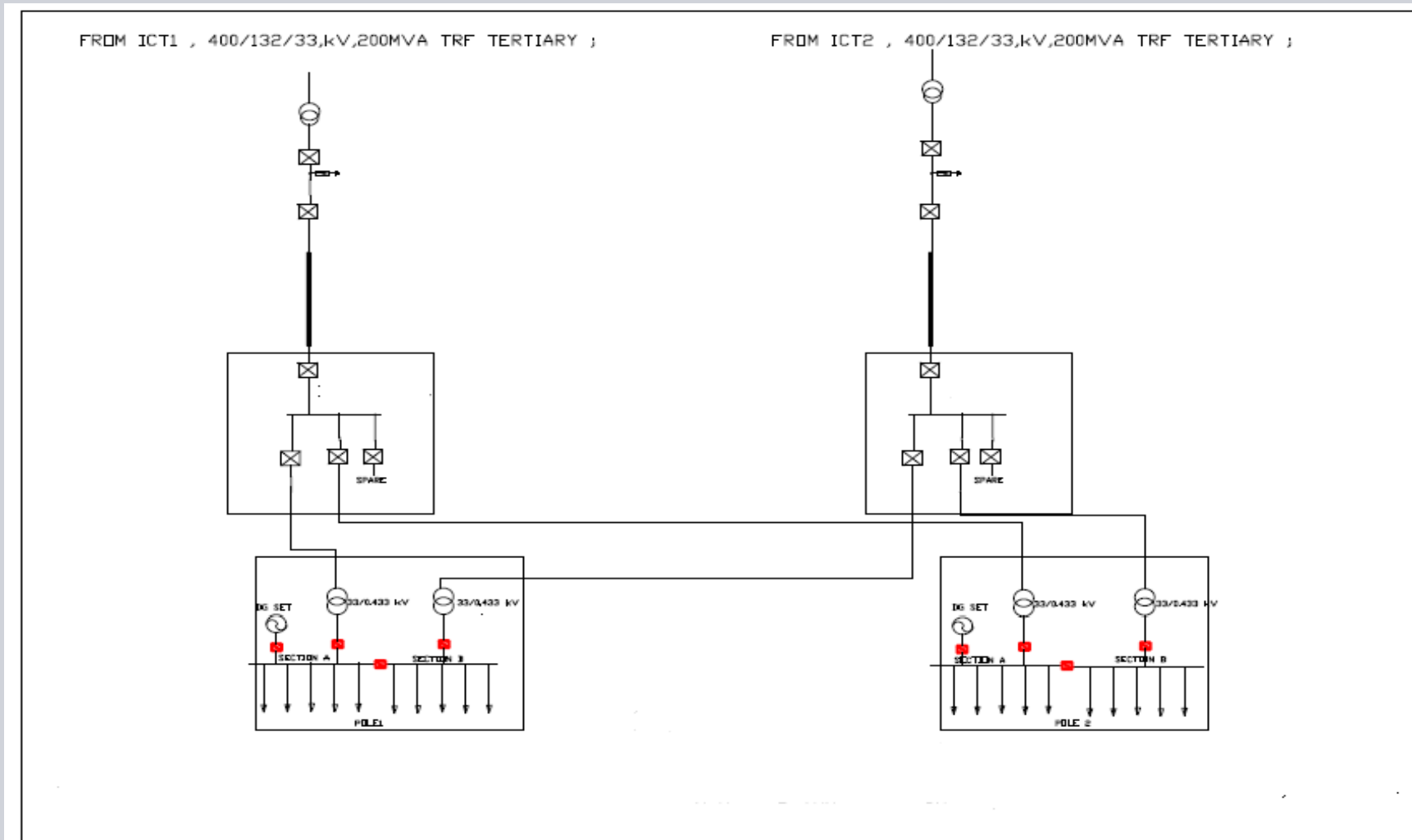

# Valve Hall Ventilation Requirements

SIEMENS

- Inside DB temperature  $50^{\circ}\text{C} \pm 2^{\circ}\text{C}$
- Inside R.H.  $43\% \pm 5\%$
- Clean room to ISO class 7 as per ISO 14644-1:1999
- Positive pressure – 3mm of water column
- Dedicated one running and one standby AHU
- Supply air through high efficiency filters to main desired clean room condition

# Fire Protection - Stages

## Fire Protection

- Fire Prevention
- Fire Detection
- Fire Fighting
- Smoke Evacuation

# Fire Protection - Design Aspects

## Fire Prevention

- Separated areas
- design of equipment
- maintenance

# Fire Protection - Choice of Material

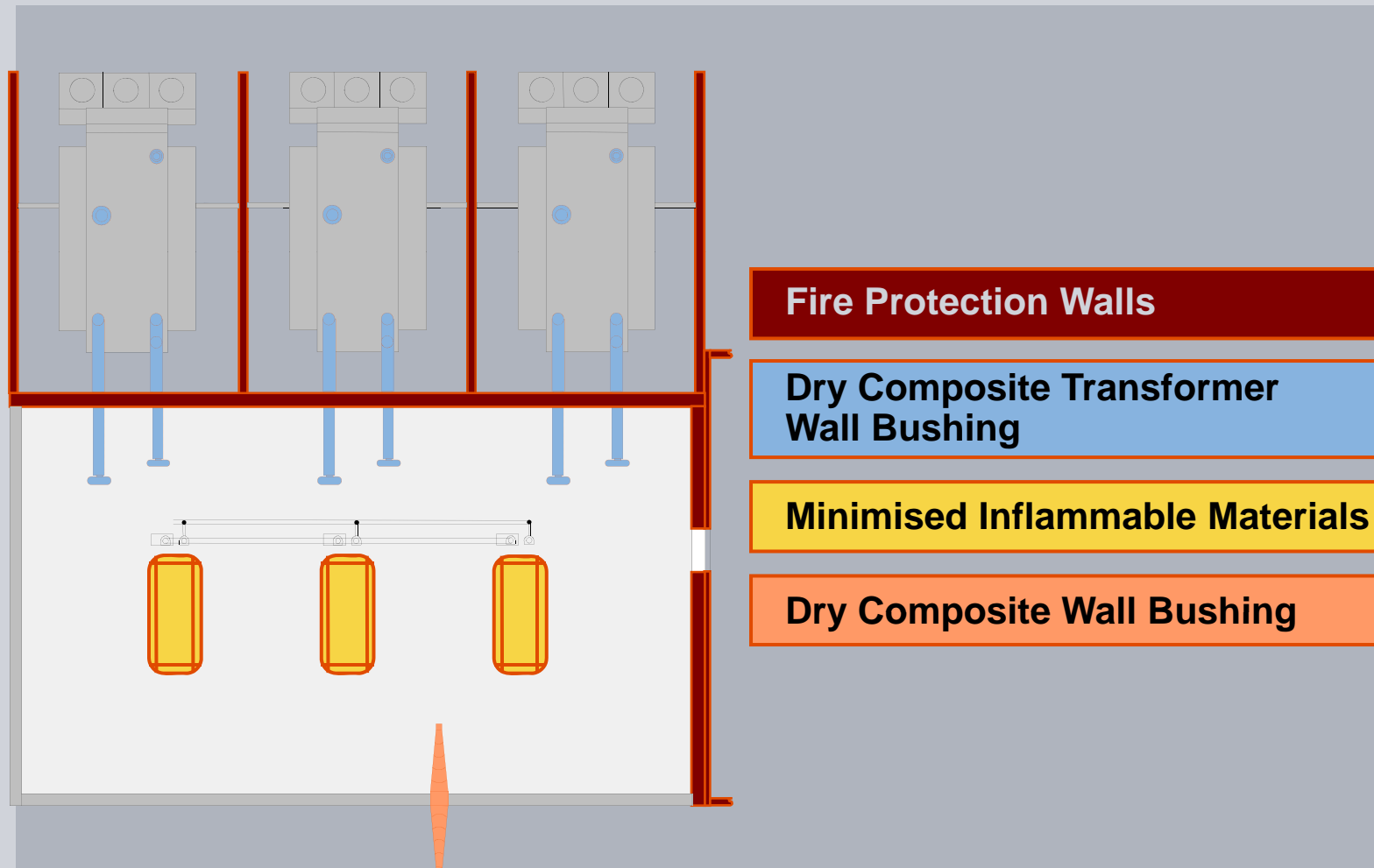

# Fire Protection - Detection

## Fire Detection

- valve hall
- transformers
- control / service building
- indication / control system

# Fire Protection - Transformers

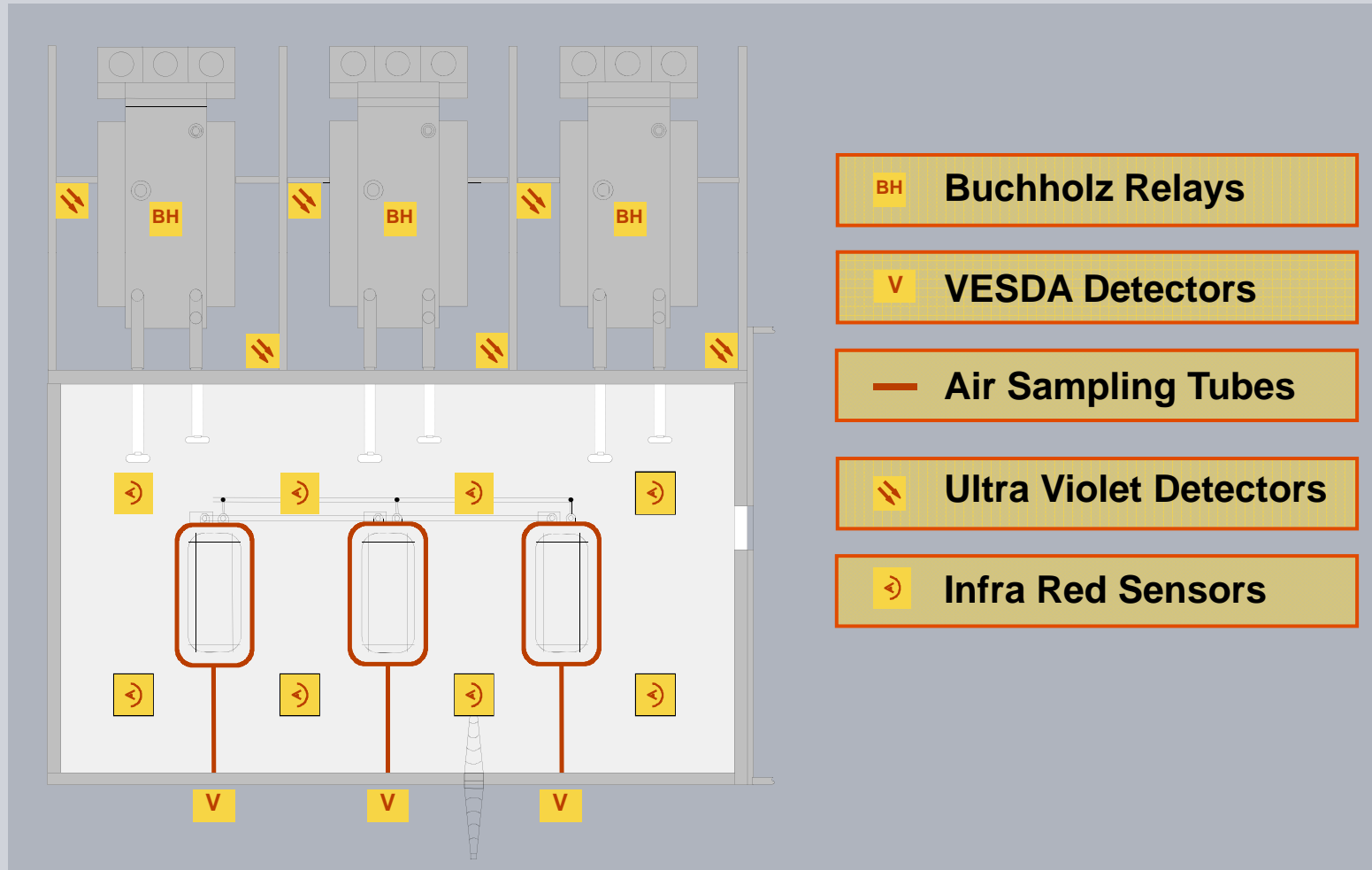

# Fire Protection - Control Rooms

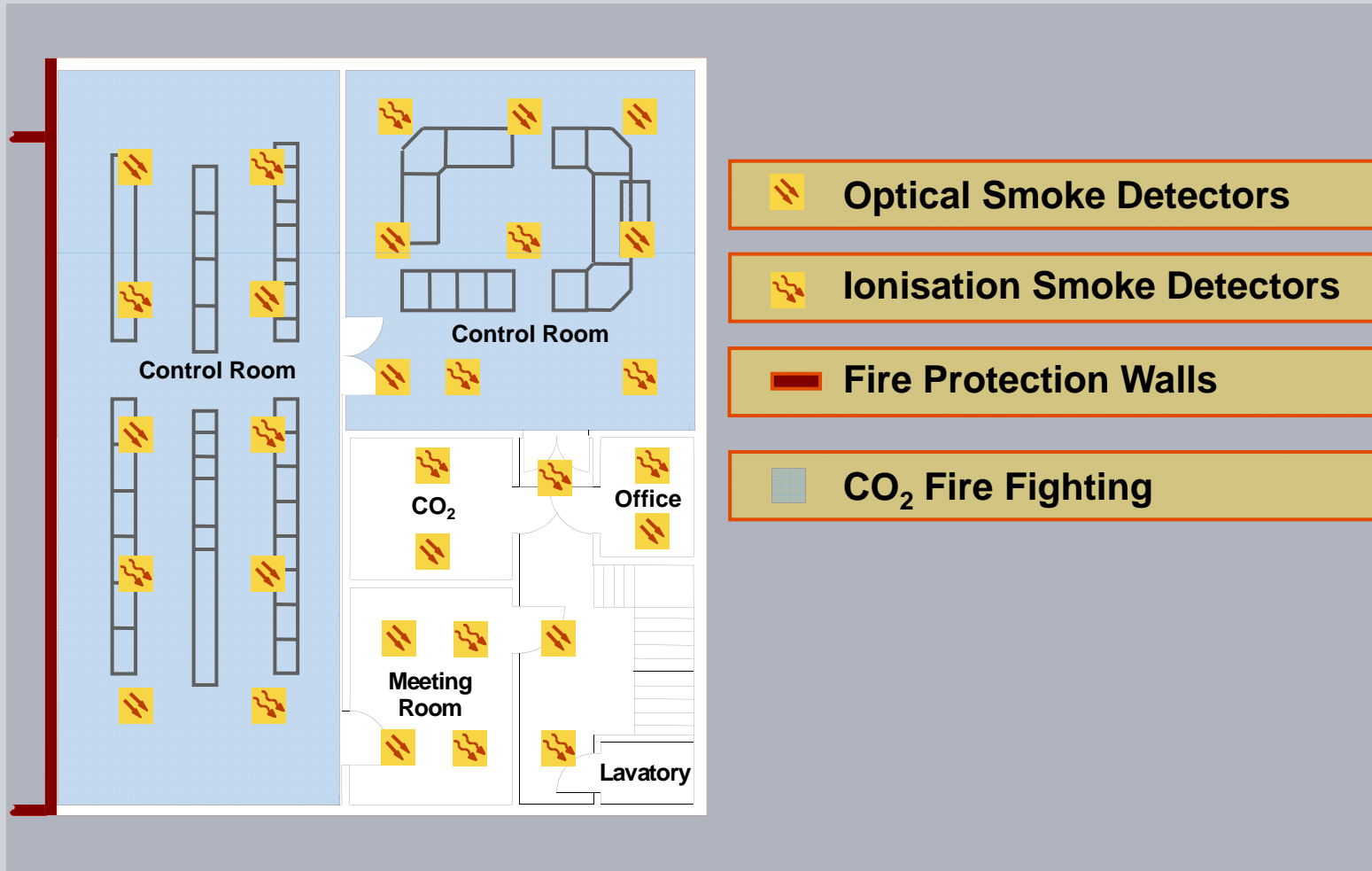

# Fire Fighting

## Technology and Installations

- deluge system
- carbondioxide (CO<sub>2</sub>)
- hydrants
- portable fire extinguishers

# Fire Protection - Deluge System

