

Black start of a passive AC network using bipolar LCC HVDC

Mats Andersson, Rong Cai, Chao Yang, ABB Corporate Research, Beijing, China

Abstract— In a general case an accident might cause complete disruption in any AC network, commonly known as blackout. For the black start of a passive network, Voltage Source Converter (VSC) is a proven technology, as shown by for instance the Cross Sound VSC HVDC link in the 2003 Northeast American blackout. Although improved by recent multi-level topologies, the general disadvantages of VSC HVDC compared to Line Commutated Converter (LCC) HVDC are still higher losses and in many cases higher total cost. In this paper a novel black start control method for a bipolar LCC HVDC transmission is derived and tested in a typical ± 800 kV UHVDC system. It is shown that the control method solves the main issues with previous thyristor based HVDC black start methods and topologies namely: high valve stress at low power levels, interstation telecommunication dependence and costly additional equipment needed. Apart from a small auxiliary power generator at the HVDC converter station, it is foreseen that no additional equipment will be needed to successfully energize and operate a passive AC network. The total amount of active power that can be delivered to the passive AC network is ~ 0.45 p.u. of the total bipolar capacity.

Index Terms— Bidirectional power flow, HVDC transmission, Power system restoration, Voltage control

I. INTRODUCTION

IN a general case an accident might cause complete disruption in any AC network, commonly known as blackout. If possible, it is attractive to restore the AC network in blackout with power from an undisturbed AC network. A point-to-point HVDC transmission is often quite long, so the probability is high that the AC network of the other HVDC station is undisturbed. For the black start of a passive network, VSC HVDC is a proven technology, as shown by for instance the Cross Sound VSC HVDC link in the 2003 Northeast blackout [1]. The black start procedure in the Estlink VSC HVDC project energizes the AC network and supplies power to a coal power plant some 200 km away from the converter station [2]. The VSC is rated 350 MVA but supplies only 10 MVA (less than 0.03 p.u. of rated power). A cold start a typical coal power plant takes 8-12 h [3]. For the black start islanded wind power generation, VSC HVDC is also a proven technology, for instance shown by the Tjæreborg VSC HVDC link [4]. Although improved by recent multi-level topologies, the general disadvantages of VSC HVDC compared to LCC HVDC are still higher losses and in many cases higher total cost. The maximum current rating obtainable with the

used IGBTs is also considerably lower than modern thyristors.

In this paper the issues with existing solutions for black start using thyristor based HVDC are identified in section II. Then the inverter commutation process is analyzed and conclusions how to obtain continuous commutation are drawn in section III. Section IV proposes a novel black start control method with both AC voltage frequency and amplitude control at the passive AC network. The control method is finally tested in a typical ± 800 kV UHVDC system and results are presented in section V. Conclusions are drawn in section VI.

II. STATE OF THE ART FOR THYRISTOR BASED HVDC BLACK START

Some solutions for black start with thyristor based HVDC has been developed [5], [6], [7]. However there are some issues that have prevented practically useful implementations.

A. High valve stress at low power levels

When starting up an AC network after a blackout, a stepwise approach with relatively small load additions is desirable and a lot of coordination with a dispatch center is typically needed. Operation starting from zero power delivered to the AC network is in many cases necessary. At zero AC power, the AC network power factor becomes completely leading due to the necessary AC filters. Hence the inverter at the passive AC network will operate with an extinction angle close to 90° . To handle this operation mode continuously, the thyristor valve needs to be made significantly more expensive, 30-40% increased voltage rating of the valve arresters with a corresponding increase in the amount of series connected thyristors. This does not only increase the cost, but also the losses in normal operation.

B. Interstation telecommunication dependence

For long distance power transmission, there is typically at least one signal relay station located in between the two converter stations. In a blackout situation, any signal relay station might also be affected by the blackout; hence no interstation communication would be possible.

C. Costly additional equipment needed

In [5], more AC and DC filters are needed due to the 6-pulse group operation. In [6], a huge STATCOM rated 0.3 p.u. of the DC power is needed.

III. THEORETICAL ANALYSIS OF THE STARTUP PROCESS

A. Comparison between normal case and black start case

Based on the assumption that the rectifier supplies a controlled DC current to the inverter, a comparison between a normal case with an external AC voltage source and the black start case is made in Table I.

B. Impedances in the commutation circuit

TABLE I
COMPARISON BETWEEN NORMAL CASE AND BLACK START CASE

| | Normal case | Black start case |
|--|---|---|
| AC voltage | Supplied by external source | A response from current injection in to AC filter and shunt connected capacitance |
| Extinction angle control | A PLL is synchronized against the external AC voltage, and then the firing instant is calculated so that desired extinction angle is achieved | None, the inverter injects current with a fixed interval (i.e. 50 or 60Hz) |
| Current leading the voltage for a successful commutation | Yes, by firing instant calculation | Is necessary, but depends on the AC load power factor. Fundamental frequency impedance of the AC network must be capacitive |

Initially it is assumed that the inverter is not connected to an external AC network yet but some AC filters are connected. The capacitance and the inductance of any AC impedance can be seen as equivalent impedance on the valve side of the converter transformer:

$$L_{valve} = \frac{1}{nr^2} * L_{ac} \quad (1)$$

$$C_{valve} = nr^2 * C_{ac} \quad (2)$$

L_{ac} = The inductive reactance at AC side

n = The number of 6-pulse converters

r = The transformer ratio

C_{ac} = The capacitive reactance at AC side

In Fig. 1 the commutation circuit of a LCC operating as an inverter is analyzed in a very similar manner to [7]. The transformer reactance and the AC filter equivalent reactance lumped together.

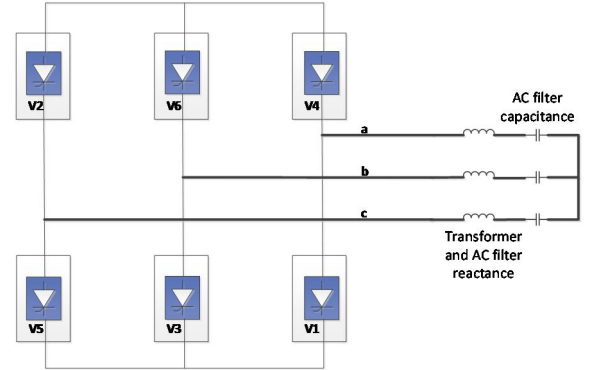

Fig. 1. A single 6-pulse group with all impedances on the transformer valve side

C. Initial commutations of the circuit

As previously mentioned, the rectifier provides a controlled current while the inverter is pulsed with an independent fixed pulse scheme (i.e. 50 or 60 Hz). The conduction path through an individual 6-pulse group is shown in Fig. 2. During the first firing, there are no residual charges in the capacitors. Valves 3 and 4 are conducting.

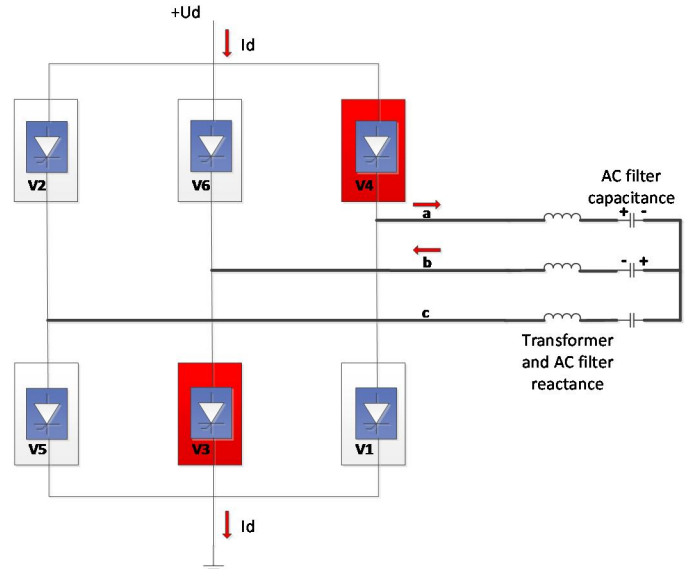

Fig. 2. Initial firing of the inverter, valves 3 and 4 are conducting

The DC current will enter the circuit in phase a, and leave through phase b. It charges the AC filter capacitor with the polarities as shown in Fig. 2. The stored charge in the and the polarity of the associated voltage facilitate both the overlap and the thyristor turn off process. After the initial firing, it is then time to commute from valve 3 to valve 5, valve 4 will keep conducting. From previous conduction interval with only valves 3 and 4 conducting, the capacitor in phase b has been charged so that there is positive polarity in direction of the normal DC current. It means that there is negative polarity in the direction of the commutation current (labelled I_{com} in Fig. 3 - Fig. 5). At the firing instant of valve 5, two parallel paths for the DC current are formed. The current will naturally shift from phase b to phase c; the charged capacitor in phase b can be viewed as a voltage source, the capacitor in phase c have no charge. This capacitor

voltage hence provides the required commutation voltage to do the first commutation. The commutation process is finished when the current flow through valve 3 decreases to zero (with a slight overshoot) and the current flow through valve 5 increases to the full DC current. An illustration of the commutation circuit at this instant is given in Fig. 3. An illustration of the phase currents is given in Fig. 4. Generally for a thyristor to turn off there must be negative polarity across it [8], and this is supplied by the charged capacitor.

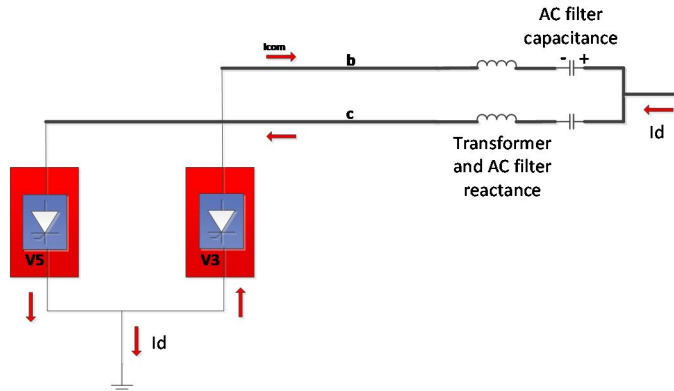

Fig. 3. Commutation from valve 3 to valve 5, assistance of phase b capacitor to achieve the commutation

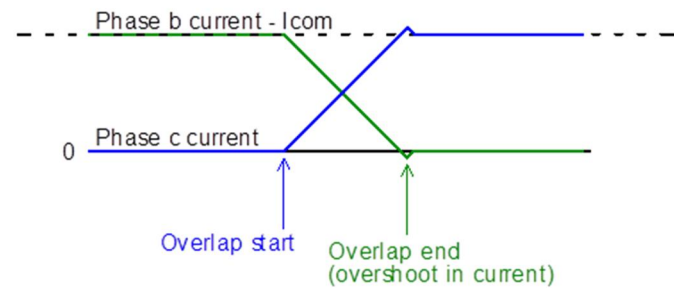

Fig. 4. Illustration of a commutation process, including overshooting current at the end. Black dashed line=DC current, Blue solid line=phase c current, Green solid line=phase b current - I_{com}

To get successful initial commutation under black start condition, it should be noticed that the total commutation capacitive reactance must be much larger than the total commutation inductive reactance. This is due to the fact that the speed of commutation process depends on the ratio of commutation voltage (this voltage in turn depends on the stored charge) and total commutation inductance. A larger total commutation capacitive reactance and smaller total commutation inductive reactance are better for successful initial commutation under black start condition. This condition will be met by normal AC filter design.

For the next commutation between valve 4 and 6, the capacitors of both phase a and b will be charged in a way that gets a higher commutation voltage, hence helping the commutation. This is shown in Fig. 5

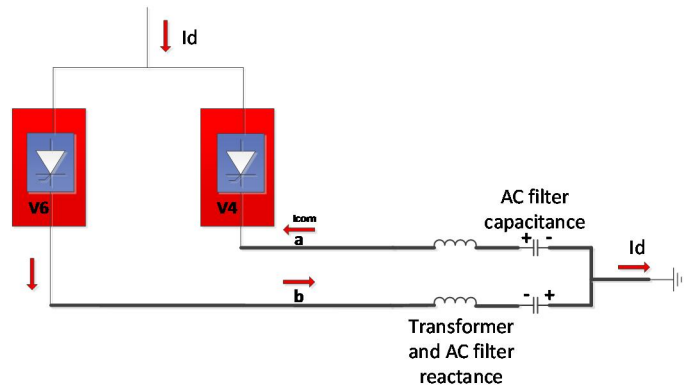

Fig. 5. Commutation from valve 4 to valve 6, assistance of both phase a and b capacitors to achieve the commutation

D. Effect of the AC load on the extinction angle

The inverter is a current source converter and will hence inject current into the AC network. The phase angle difference between the injected current and the AC voltage response is hence dependent on the power factor of the AC system. Assuming that commutation is successful, this has the following consequences:

- If fully inductive load, the current is lagging the AC voltage by 90° .
- If fully resistive load, the current and AC voltage are in phase.
- If fully capacitive load, the current is leading the AC voltage by 90° .

After the initial commutation process discussed in section C, continuous commutation is necessary for black start. In order to successfully commute, the current must be leading the AC voltage; the thyristor always needs a high enough extinction angle. A slightly leading AC load power factor is desirable in the black start situation. It re-creates the typical conditions under which the thyristor valve normally operates. If the AC load power factor is not slightly leading, it will have the following consequences:

- If the AC load power factor is close to unity, the extinction angle will be too low and commutation will consequently fail.
- If the AC load power factor is very leading, the extinction angle will be very high, which is not sustainable in steady state operation without making the thyristor valve much more expensive.

If a resistive AC load is connected as shown in Fig. 6, the resistors will discharge the AC filter capacitors continuously. To get initial commutation going it should be preferable to not have any resistive AC load connected since it will discharge AC filters. Once commutation has been well established, resistive loads can be added.

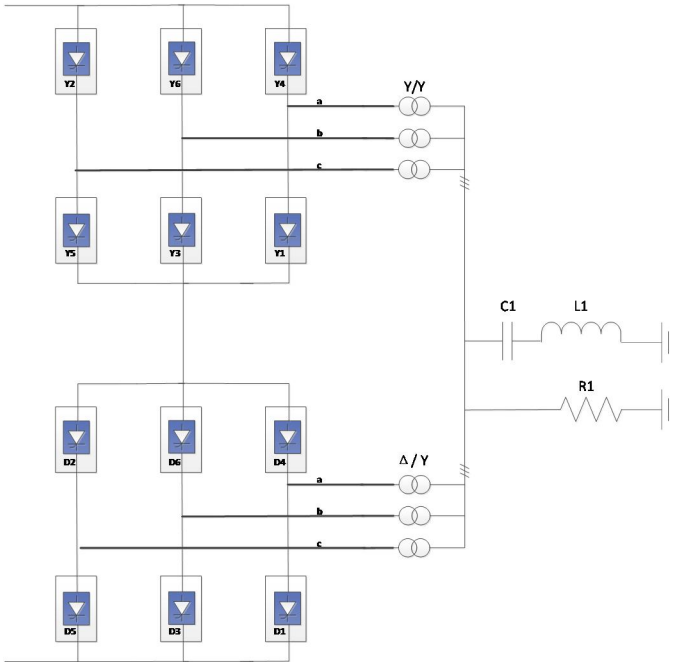

Fig. 6. Resistive AC load (R1) in parallel with an AC filter (C1 and L1)

IV. SYSTEM TOPOLOGY AND CONTROL ALLOCATION FOR BLACK START

A. Overall control objectives

Once the system has started up and is commutating continuously, there is a need to control both the AC voltage frequency and amplitude. The extinction angle also needs to be controlled; neither too small nor too big. Frequency control will naturally be provided by the fixed pulsing scheme of the inverter. An amplitude control method that overcomes the main problems in existing solutions needs to be developed.

B. Proposed system topology – bipolar transmission

In order to keep an acceptable extinction angle a bipolar topology is used, shown in Fig. 7. The naming scheme is where S_x refers to station (S1 or S2) and P_y refers to pole (P1 P2). The main approach used is to inject current with pole 1 draw back current with pole 2. The objective is to get

neither too small nor too big extinction angle in S2P1 regardless of active power need in the S2 AC network.

C. Control method

S1 AC network is normal; S2 AC network is completely passive. P1 is operating in normal power direction; P2 is operating in reversed power direction.

- S1P1 is a DC current controlling rectifier
- S1P2 is a DC voltage controlling inverter
- S2P1 is an inverter using a simple fixed pulsing system of either 50 or 60 Hz, it does not perform any dedicated DC voltage control
- S2P2 is an AC voltage amplitude controlling rectifier

The overall control objectives of all converters are the following, listed in priority order:

- Continuous commutation of S2P1
- S2 AC voltage amplitude regulation
- Acceptable steady state extinction angle in S2P1

As previously discussed, the power factor of the AC network in S2 needs to be slightly leading for optimal operation. This matches well with the fact that the poles are operating in different power directions.

- In black start mode the minimum power delivered to the AC network in S2 must be 0.0 p.u of bipolar capacity, which can be done by transmitting the same amount of power in both poles.
- In black start mode the maximum power delivered to the AC network in S2 will be roughly ~ 0.45 p.u of bipolar capacity, $+0.5$ p.u in forward direction with pole 1 and -0.05 p.u in reverse power direction with pole 2.

Hence a DC power absolute value sum of around ~ 0.55 p.u of bipolar capacity could be used for either minimum or maximum AC power, just a different power share between the two poles. This is important since the combined reactive power consumption of both converters should not change that much even though the active power delivered to the AC network in S2 will change considerably.

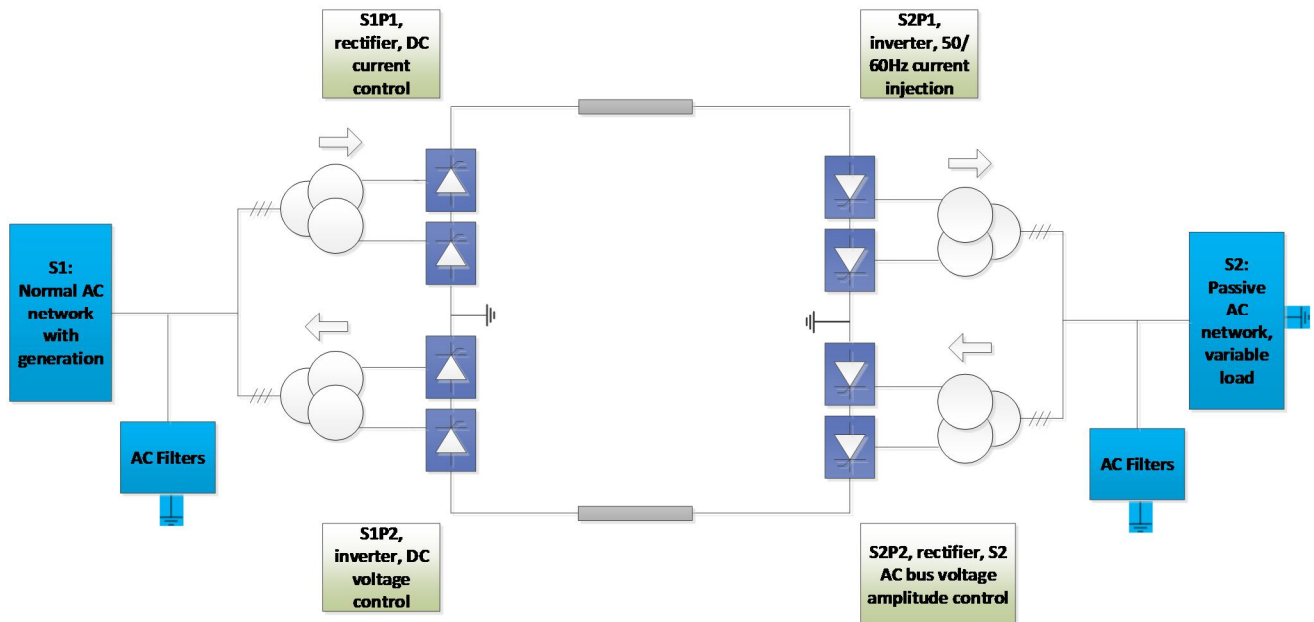

Fig. 7. Proposed bipolar system topology and control method

There must already be enough reactive power supply through filters and shunt capacitors to handle 1.0 p.u of bipolar capacity in either direction for normal operation. This means that there is already enough reactive power supply for the active power levels achievable with the suggested topology. This reactive power supply is needed to form the desired slightly leading power factor.

V. CASE STUDY – BLACK START OF A PASSIVE AC NETWORK

A. System configuration

The key data for the system is shown in Table II. A typical UHVDC pole consists of two 12-pulse groups in series, which was also used in the testing.

B. Considerations for initial startup

TABLE II
KEY DATA FOR THE SYSTEM USED IN THE CASE STUDY

| | S1 | S2 | DC |
|-----------------------------|-------------|-------------|----------|
| Type | Bipole | Bipole | - |
| AC voltage | 750kV, 50Hz | 750kV, 50Hz | - |
| AC Short Circuit Ratio | 10 | 0 (passive) | - |
| Bipolar power capacity | 7000 MW | 7000 MW | - |
| Nominal DC voltage | - | - | ±800kV |
| Nominal DC current | - | - | 4.375 kA |
| DC Transmission line length | - | - | 2400 km |

As a precondition of black start, almost all of the AC filters and shunt capacitors in S2 needs to be connected, and no external AC loads should be connected. Connection of almost every capacitive element offers the maximum commutation capacitance, which consequently aids the initial A total of 2795 Mvar or ~0.4 p.u was hence connected.

The tap changer in S2P1 is set to give a bit lower U_{di0} than nominal. With a lower U_{di0} , a higher than nominal extinction angle can be used without violating the allowed valve stress. There is no designated DC voltage control in P1. Assuming that S2 AC voltage amplitude is controlled to its nominal value, S1P1 DC voltage will depend on the S2P1 tap changer position, P1 DC current and the DC line resistance. Due to the lower U_{di0} the DC voltage will be a bit lower than nominal. Initial current order in pole 1 is set to ramp from 0.1 to 0.6 p.u, this will eventually give roughly ~0.55 p.u of nominal pole power. The DC voltage reference in S1P2 is reduced a bit as to match the DC voltage of P1, which eliminates the ground current for the no load condition. This also ensures that the voltage of S2P2 must still be fairly high before any DC current will flow. To get a fairly high DC voltage in S2P2, the AC voltage amplitude in S2 must also be fairly high. This way S2P2 will not draw active nor reactive power until the difficult initial commutations are successful and an AC voltage has established. The simulation results are shown in Fig. 8 and Fig. 9.

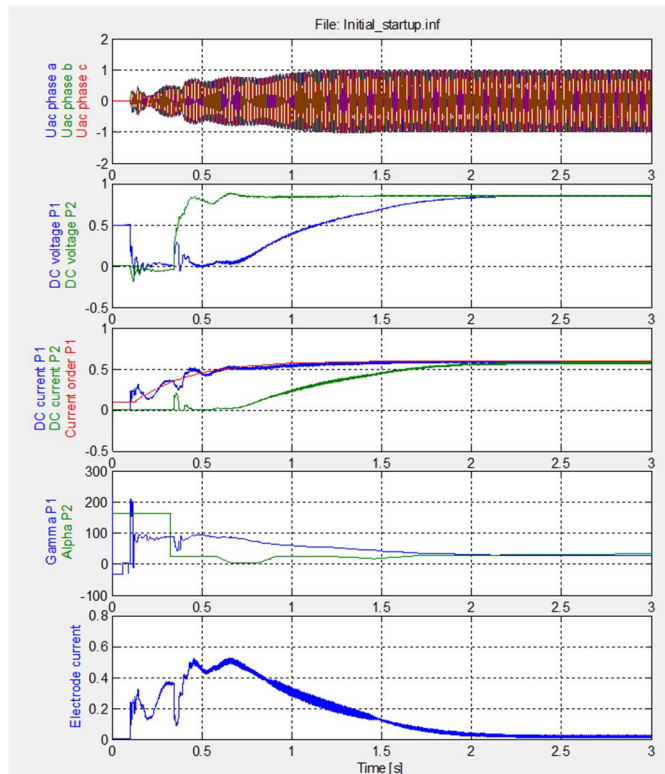

Fig. 8. Initial startup to no load in S2, S2 graphs. Graph 1: AC bus voltage. Graph 2: Blue=P1 DC voltage, Green=P2 DC voltage. Graph 3: Blue=P1 DC current, Green=P2 DC current, Red=S1P1 current order. Graph 4: Blue=S2P1 valve extinction angle, Green=S2P2 alpha measured. Graph 5: Blue=S2 electrode current. Graph 4 in electrical degrees, all others in p.u.

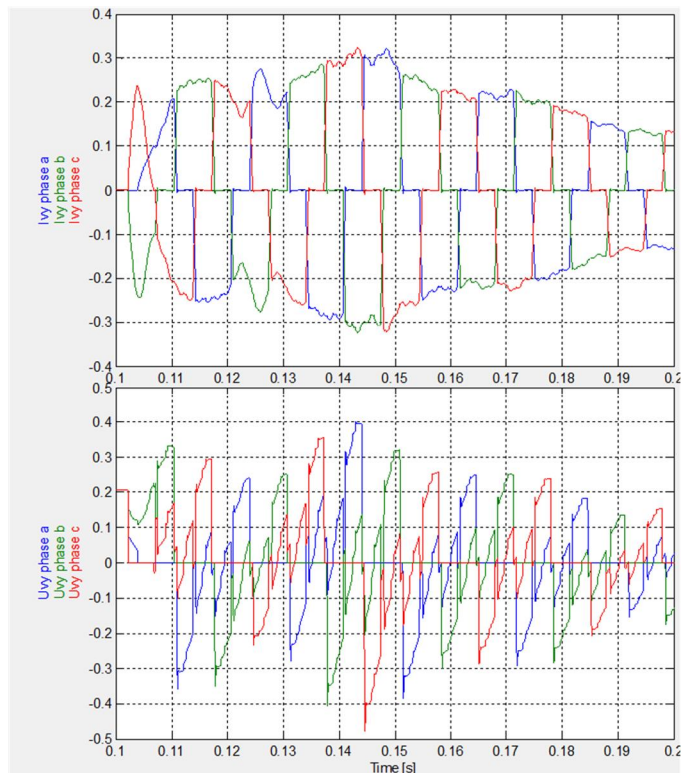

Fig. 9. Initial startup to no load, S2P1 low voltage Y-group quantities. Graph 1: Valve currents. Graph 2: Valve voltages. All graphs in p.u.

C. Analysis of the initial startup

S1P1 and S1P2 are already deblocked prior to deblocking the S2 converters. In particular, S1P1 is a rectifier but operating in an OLT (Open Line Test) DC voltage control mode, the voltage reference is set to 0.5 p.u. The reason for this is that in reality the 6" thyristors typically used for UHVDC are electrically fired, not optically fired. The DC voltage from the rectifier will hence pre-charge the Thyristor Control Unit in S2P1. S1P2 already operates as a deblocked inverter and has a quite high DC voltage reference, around 0.8 p.u. S2P1 is then deblocked at around 0.11s. In this particular simulation, valve 5 and 6 are initially conducting. Then valve 1 is fired and the first commutation starts. The first overlap is relatively long ($\sim 52^\circ$) since there is not much stored charge in the phase c capacitor. The overlap for the second commutation is much shorter ($\sim 7.5^\circ$) since charge has been stored in both the capacitors of phase a and phase c.

S2P2 is then deblocked as a rectifier when the AC voltage reaches around 0.5 p.u at around 0.35 s. An overview of the voltage amplitude PI controller regulator is given in Fig. 10.

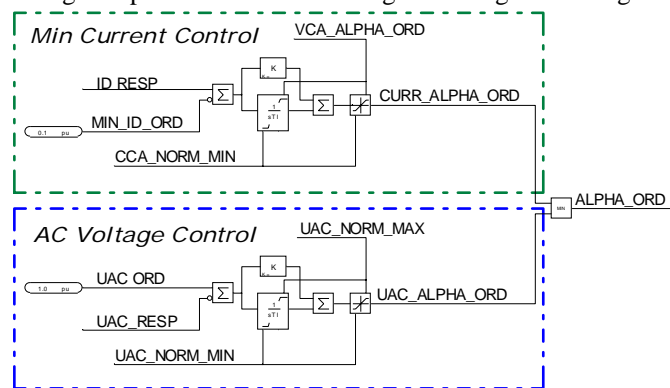

Fig. 10. S2P2 AC voltage and minimum DC current controls, and cooperation method

The total power injected into the S2 AC network by P1 is larger than what is drawn by P2. Because of this the AC voltage will build up smoothly, mostly following the ramping current order in S1P1.

When starting up under the no load condition, the passive network with almost all AC filters and shunt capacitors connected is capacitive for the fundamental frequency. It can be seen in gamma of S2P1 which is initially very high (approximately 90°). When the DC current of P2 increases, the active and reactive power consumption increases and gamma in S2P1 goes down to a lower level (approximately 30°). This in turn increases the DC voltage of P1 which injects more active power in to the AC network.

VI. CONCLUSION

In this paper a novel bipolar black start control method generally applicable for any bipolar LCC HVDC was derived. A basic case study was made, and initial startup of the system shows that the steady state thyristor valve stress is likely to be manageable. This was the key problem with existing solutions. The control method does not rely on interstation communication, which was another relatively large problem

with existing solutions. Apart from a small auxiliary power generator at the HVDC converter station, it is foreseen that no additional equipment will be needed to successfully energize the converter AC bus.

Further dynamic studies including load addition, load rejection, AC faults, and DC faults are needed to find out the robustness of the suggested control method.

REFERENCES

- [1] M. Bahrman, P-E. Björklund, "The New Black Start: System Restoration with Help from Voltage-Sourced Converters", IEEE Power and Energy Magazine, Volume 12, Issue 1, Jan. 2014.
- [2] Ying Jiang-Häfner et. al., "HVDC with voltage source converters - a powerful standby black start facility", IEEE/PES, Chicago, USA, April 2008.
- [3] Karin Oskarsson et. al. "A planner's guide for selecting clean-coal technologies for power plants", World Bank technical paper ; no. WTP 387. Washington, D.C, 1997
- [4] A-K. Skytt, P. Holmberg, L-E. Juhlin, "HVDC Light for connection of wind farms", Second International Workshop on Transmission Networks for Off shore Wind Farms Royal Institute of Technology Stockholm, Sweden, March 29-30, 2001
- [5] H.M. Turanli, R.W. Menzies, D.A. Woodford, "Feasibility of DC Transmission with Forced Commutation to Remote Loads", IEEE Transactions on Power Apparatus and Systems, Vol. PAS-103, No. 6, June 1984.
- [6] Bjarne R. Andersen, Lie Xu, "Hybrid HVDC system for power transmission to Island networks", IEEE Transactions on Power Delivery, Vol. 19, No. 4, October 2004.
- [7] M. Mohaddes et. al. "Supplying Dead Load with a Conventional HVDC System", Proceedings of CIGRE Colloquium on Role of HVDC, FACTS and Emerging Technologies in Evolving Power Systems, Bangalore, India, Sep. 2005.
- [8] N. Mohan, T. Undeland, W. Robbins, "Thyristors" in *Power Electronics, Converters, Applications and Design*, 2nd ed., New York, John Wiley & Sons, 1995, Chapter 23



Per Matts Ove Andersson was born in Hudiksvall, Sweden, in 1978. He received the B.Sc. degree in electrical engineering from Mälardalens University, Ludvika, Sweden in 2001. After graduation to present date he has held various positions in ABB, all related to HVDC. Currently he is a principal scientist at ABB Corporate Research Center in Beijing, China. His

main fields of interest are HVDC, power electronics and systems, with a focus on integration of renewable energy. Email: mats.andersson@cn.abb.com